



MegaLife



Owner's Manual

Original Instructions 
Air Conditioners

Air-to-water Heat Pump Monobloc Type

Thank you for choosing commercial air conditioners. Please read this Owner's Manual carefully before operation and retain it for future reference.

If you have lost the Owner's Manual, please contact the local agent or visit www.megalife.ma

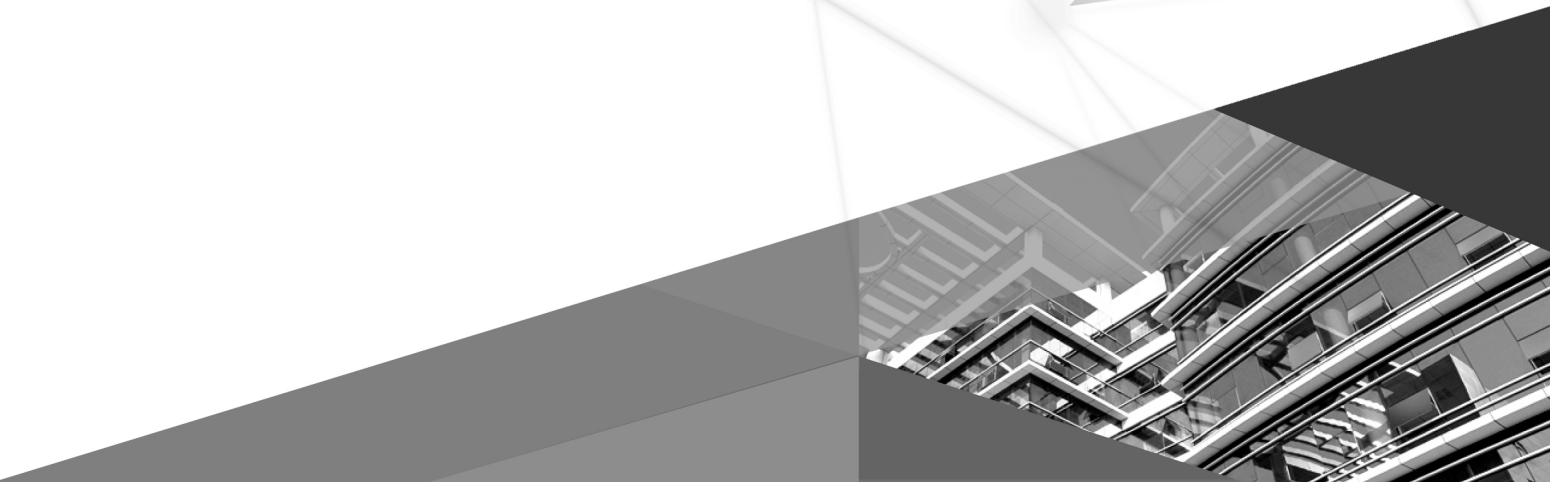
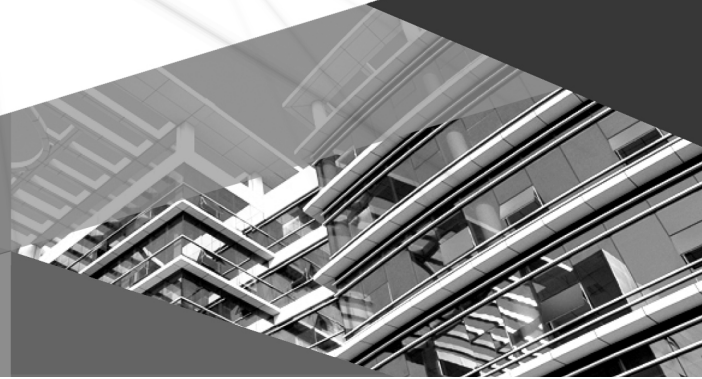

To Users

Thank you for selecting our product. Please read this instruction manual carefully before installing and using the product, so as to master and correctly use the product. In order to guide you to correctly install and use our product and achieve expected operating effect, we hereby instruct as below:

- (1) This equipment should be installed, operated or maintained by the qualified servicemen who have had specific training. During operation, all safety issues covered in the labels, User's Manual and other literature should be followed strictly. This equipment is not intended for use by persons (including children) with reduced physical, sensory or mental capabilities, or lack of experience and knowledge, unless they have been given supervision or instruction concerning use of the appliance by a person responsibility for their safety. Children should be supervised to ensure that they do not play with the appliance.
- (2) This product has gone through strict inspection and operational test before leaving the factory. In order to avoid damage due to improper disassembly and inspection, which may impact the normal operation of unit, please do not disassemble the unit by yourself. You can contact with the special maintenance center of our company if necessary.
- (3) For personal injury or property loss and damage caused by improper operation such as improper installation and debugging, unnecessary maintenance, violation of related national laws and rules and industrial standard, and violation of this instruction manual, etc., we will bear no liability.
- (4) When the product is faulted and cannot be operated, please contact with our maintenance center as soon as possible by providing the following information.
 - Contents of nameplate of product (model, cooling/heating capacity, product No., ex-factory date).
 - Malfunction status (specify the situations before and after the error occurs).
- (5) All the illustrations and information in the instruction manual are only for reference. In order to make the product better, we will continuously conduct improvement and innovation. We have the right to make necessary revision to the product from time to time due to the reason of sales or production, and reserve the right to revise the contents without further notice.
- (6) The final right to interpret for this instruction manual belongs to MegaLife.

Contents

Safety Notices (Please be sure to abide)	1
1. Diagram of the Operating Principle	7
2. Operating Principle of the Unit	8
3. Nomenclature	10
4. Installation Example	11
5. Main Components	13
6. Installation Guideline of the Unit	15
6.1 Instruction to installation	15
6.2 Installation of the Monobloc Unit.....	15
6.3 Water Volume and Pump Capacity (with pump)	17
6.4 Water Volume and Expansion Vessel Pressure.....	18
6.5 Selection of Expansion Vessels	18
7. Remote Air Temperature Sensor	19
8. Thermostat	20
9. 2-Way Valve	20
10. 3-Way Valve	21
11. Wired Controller	22
12. Other Auxiliary Heat Sources	22
13. Gate-controller	22
14. Charging and Discharging of Refrigerant	23
15. Installation of Insulated Water Tank	24
15.1 Installation measure.....	24
15.2 Outline dimension and parameter of water tank	25
15.3 Connection of waterway system	26
15.4 Electric wiring work	27
16. Wring Diagram	28
16.1 Control Board.....	28
16.2 Electric Wiring.....	35
17. Commissioning	37
17.1 Check before startup.....	37
17.2 Test run	38
18. Daily Operation and Maintenance	39

Safety Notices (Please be sure to abide)

 **WARNING:** If not abide strictly, it may cause severe damage to the unit or the people.

 **NOTE:** If not abide strictly, it may cause slight or medium damage to the unit or the people.

 This sign indicates that the operation must be prohibited. Improper operation may cause severe damage or death to people

 This sign indicates that the items must be observed. Improper operation may cause damage to people or property.

NOTE

After receipt of the unit, check it for appearance, unit model compared with your desire and attachments.

Design and installation work of the unit must be performed by authorized personnel according to applicable laws and regulations and this Instruction.

After installation work, the unit cannot be energized unless there is not any problem in check.

Ensure periodical clean and maintenance of the unit after normal operation of the unit for longer life and reliable operation.

If the supply cord is damaged, it must be replaced by the manufacturer, its service agent or similarly qualified persons in order to avoid a hazard.

The appliance shall be installed in accordance with national wiring regulations.







This product is a kind of comfort air conditioning, and is not allowed to be installed where there are corrosive, explosive and inflammable substances or smog; otherwise it would lead to operation failure, shortened service life, five hazard or even severe injuries. Special air conditions are required for where mentioned above.



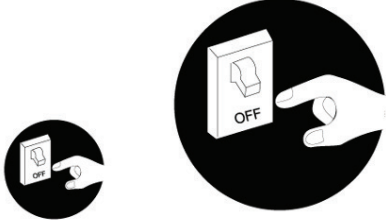



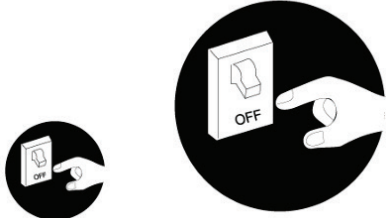

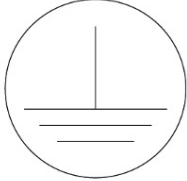
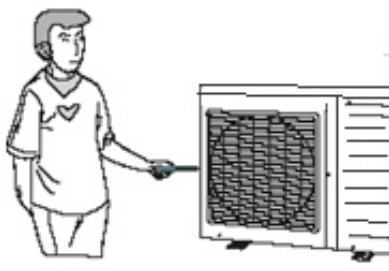

Correct Disposure

This marking indicates that this product should not be disposed with other household wastes throughout the EU. To prevent possible harm to the environment or human health from uncontrolled waste disposal, recycle it responsibly to promote the sustainable reuse of material resources. To return your used device, please use the return and collection systems or contact the retailer where the product was purchased. They can take this product for environmental safe recycling.

R410A(R32/125:50/50):2087.5

⚠ WARNING		
<p>Once abnormality like burning smell occurs, please cut off the power supply immediately and then contact with service center.</p>  <p>If the abnormality still exists, the unit may be damaged and electric shock or fire may result.</p>	<p>Don't operate the unit with wet hand.</p>  <p>Otherwise, it may cause electric shock.</p>	<p>Before installation, please see if the voltage of local place accords with that on nameplate of unit and capacity of power supply, power cord or socket is suitable for input power of this unit.</p> 
<p>Special circuit must be adopted for power supply to prevent fire.</p>  <p>Do not use octopus multipurpose plug or mobile terminal board for wire connection.</p>	<p>Be sure to pull out the power plug and drain the indoor unit and water tank when unit is not in use for a long time.</p>  <p>Otherwise, the accumulated dust may cause overheating, fire or freeze of water tank or coaxial heater exchanger in winter.</p>	<p>Never damage the electric wire or use the one which is not specified.</p>  <p>Otherwise, it may cause overheating or fire.</p>

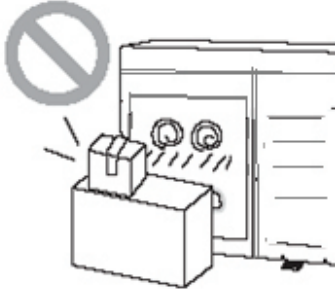
<p>Before cleaning please cut off the power supply.</p>   <p>Otherwise, it may cause electric shock or damage.</p>	<p>The power supply must adopt special circuit with leakage switch and enough capacity.</p>	<p>User can not change power cord socket without prior consent. Wiring working must be done by professionals. Ensure good earthing and don't change earthing mode of unit.</p>
<p>Earthing: the unit must be earthed reliably ! The earthing wire should connect with special device of buildings.</p>   <p>If not, please ask the qualified personnel to install. Furthermore, don't connect earth wire to gas pipe, water pipe, drainage pipe or any other improper places which professional does not recognize.</p>	<p>Never insert any foreign matter into outdoor unit to avoid damage . And never insert your hands into the air outlet of outdoor unit.</p> 	<p>Don't attempt to repair the unit by yourself.</p>   <p>Improper repair may cause electric shock or fire, so you should contact the service center to repair.</p>

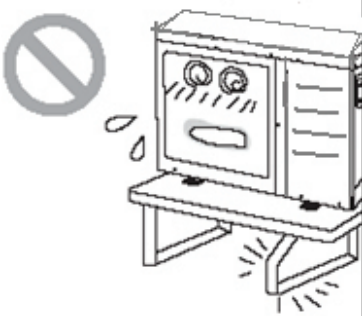
<p>Don't step on the top of the unit or place anything on it.</p>  <p>There is the danger of fall of things or people.</p>	<p>Never block the air inlet and outlet of unit.</p>  <p>It may reduce efficiency or cause stop of the unit and even fire.</p>	<p>Keep pressurized spray, gas holder and so on away from the unit above 1m .</p>  <p>It may cause fire or explosion.</p>
<p>Please note whether the installation stand is firm enough or not.</p>  <p>If damaged, it may cause fall of the unit and injury of people.</p>	<p>Unit should be installed at the place with good ventilation to save energy.</p>	<p>When there is not water in water tank, never power the unit on to run.</p>

 **NOTE**

Before installation, please check if the adopted power is accordance with that listed on nameplate, and check the safety of power.

The unit shall contact with the supply mains by a full disconnection device under overvoltage category III .

Before using, please check and confirm if wires and water pipes are connected correctly to avoid water leakage, electric shock or fire etc.

Don't operate the unit with wet hand, and don't allow children to operate the unit.

The On/off in the instruction is for the operation to on and off button of PCB for users; cut off power means to stop supplying power to the unit.

Don't directly expose the unit under the corrosive ambient with water or dampness.

Don't operate the unit without water in water tank .The air outlet/inlet of unit cannot be blocked by other objects.

The water in unit and pipeline should be discharged if the unit is not in use, to prevent the water tank, pipe line and water pump from frost-cracking.

Never press the button with sharp objects to protect manual controller. Never use other wires instead of special communication line of the unit to protect control elements. Never clean the manual controller with benzene, thinner or chemical cloth to avoid fading of surface and failure of elements. Clean the unit with the cloth soaked in neutral eradicator. Slightly clean the display screen and connecting parts to avoid fading.

The power cord must be separated with the communication line.

maximum and minimum water operating temperatures.

Item	Minimum water operating temperatures	Maximum water operating temperatures
Cooling	7°C	25°C
Heating	25°C	55°C
Water heating	40°C	80°C

maximum and minimum water operating pressures.

Item	Minimum water operating pressures	Maximum water operating pressures
Cooling	0.05MPa	0.25MPa
Heating		
Water heating		

maximum and minimum entering water pressures.

Item	Minimum entering water pressures	Maximum entering water pressures
Cooling	0.05MPa	0.25MPa
Heating		
Water heating		

The range of external static pressures at which the appliance was tested (add-on heat pumps, and appliances with supplementary heaters, only); If the supply cord is damaged, it must be replaced by the manufacturer, its service agent or similarly qualified persons in order to avoid a hazard.

The appliance is intended to be permanently connected to the water mains and not connected by a hose-set.

If there is any question, please contact with local dealer, authorized service center, agencies or our company directly.

1. Diagram of the Operating Principle

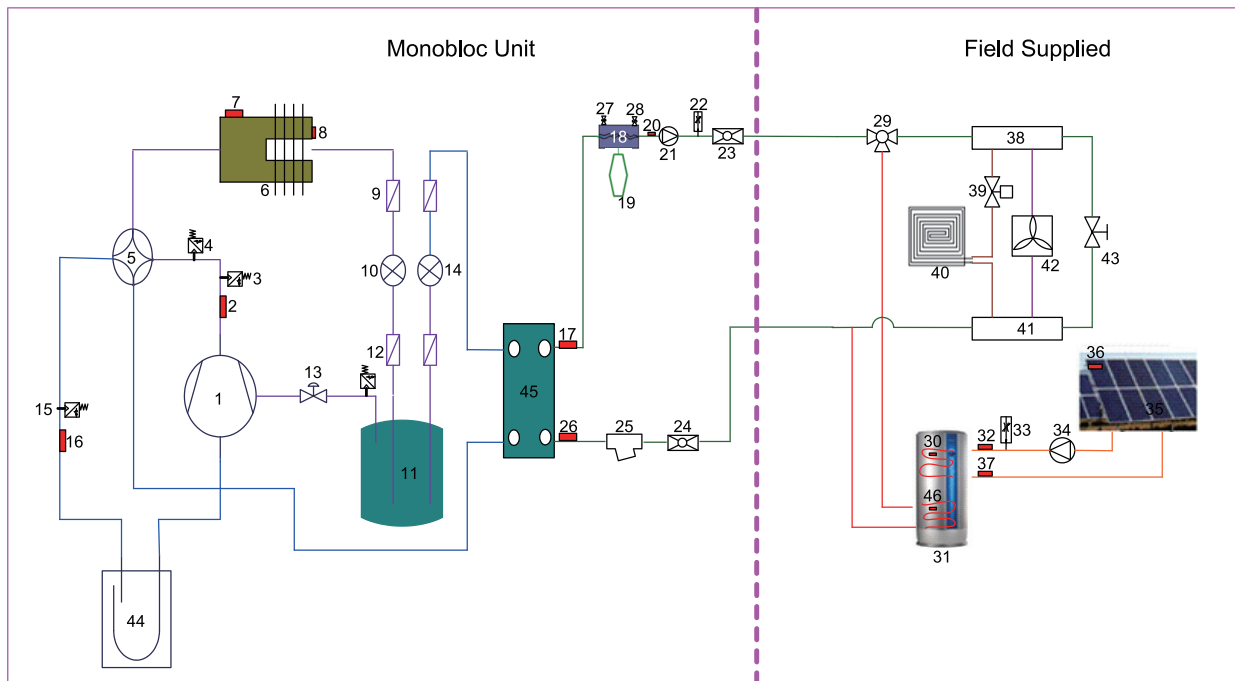

No.	Name	No.	Name	No.	Name	No.	Name
1	Inverter compressor	13	Solenoid valve	25	Water filter	37	Solar system inlet temperature sensor
2	Discharge temperature sensor	14	EXV 2	26	Inlet temperature sensor (plate heat exchanger)	38	Water separator
3	High-pressure switch	15	Low pressure sensor	27	Safety valve	39	2-way Valve 1
4	High pressure sensor	16	Suction temperature sensor	28	Exhaust valve	40	Floor radiator
5	4-way Valve	17	Outlet water temperature sensor (plate heat exchanger)	29	3-way valve 2	41	Water collector
6	Finned heat exchanger	18	Auxiliary electric heater	30	Water tank temperature sensor 1	42	FCU
7	Environment temperature sensor	19	Expansion tank	31	Water tank	43	By-pass valve
8	Defrosting temperature sensor	20	Main outlet temperature sensor	32	Solar system outlet temperature sensor	44	Vapor liquid separator
9	Filter	21	Main water pump	33	Solar system flow switch	45	Main plate heat exchanger
10	EXV 1	22	Main flow switch	34	Solar system water pump	46	Water tank temperature sensor 2
11	Flasher	23	Outlet pipe connector	35	Solar panel		
12	Pressure sensor	24	Inlet pipe connector	36	Solar panel temperature sensor		

2. Operating Principle of the Unit

DC Inverter Air to Water Heat Pump is composed of the unit,FCU and water tank. Operation functions:

(1) Cooling;

Cooling: in cooling mode, the refrigerant is condensed in the aluminum fin-copper tube and evaporated in the plate heat exchanger. Via the heat exchange with water in the plate heat exchanger, the temperature of water decrease and it releases heat while the refrigerant absorbs heat and evaporates. With the help of wired controller, the outflow temperature can meet the user's requirement. Through the control of valve, the low-temperature water in the system is connected with indoor fan coil and underground pipe, and exchanges heat with the indoor air so that the indoor temperature decreases to the required range.

(2) Heating;

Heating: in heating mode, the refrigerant evaporates in the aluminum fin-copper tube and is condensed in the plate heat exchanger. Via the heat exchange with water in the plate heat exchanger, the water absorbs heat and its temperature increase while the refrigerant releases heat and is condensed. With the help of wired controller, the outflow temperature can meet the user's requirement. Through the control of valve, the high-temperature water in the system is connected with indoor fan coil and underground pipe, and exchanges heat with the indoor air so that the indoor temperature increases to the required range.

(3) Water heating;

Water heating: in water heating mode: the refrigerant evaporates in the aluminum fin-copper tube and is condensed in the plate heat exchanger. Via the heat exchange with water in the plate heat exchanger, the water absorbs heat and its temperature increase while the refrigerant releases heat and is condensed. With the help of wired controller, the outflow temperature can meet the user's requirement. Through the control of valve, the high-temperature water in the system is connected with the coil pipe of bearing water tank, and exchanges heat with the water in the water tank so that the temperature of water tank increases to the required range.

(4) Cooling +water heating;

Cooling + water heating: when cooling mode exists together with the water heating mode, the user can set the priority of these two modes based on the needs. The default priority is heat pump. That is under the default setting, if cooling mode exists together with the water heating mode, the heat pump gives priority to cooling. In that case, water heating can only realized with e-heater of the water tank. Inversely, the heat pump gives priority to water heating and switches to cooling after finishing water heating.

(5) Heating+ water heating;

Heating+ water heating: when heating mode exists together with the water heating mode, the user can set the priority of these two modes based on the needs. The default priority is heat pump. That is under the default setting, if heating mode exists together with the water heating mode, the heat pump gives priority to heating. In that case, water heating can only realized with e-heater of the water tank. Inversely, the heat pump gives priority to water heating and switches to heating after finishing water heating.

(6) Emergency mode;

Emergency mode: this mode is only available for heating and water heating. When the monobloc unit stops due to malfunction, enter the corresponding emergency mode; as to heating mode, after entering the emergency mode, heating can only be realized through e-heater .When the setting outflow temperature or indoor temperature is reached, the e-heater will stop running; as to water heating mode, the e-heater stops while the e-heater of water tank runs. When the setting temperature or water tank is reached, the e-heater will stop running.

(7) Quick water heating;

Quick water heating: in quick water heating mode, the unit runs according to the water heating control of heat pump and the e-heater of water tank runs at the same time.

(8) Holiday mode;

Holiday mode: this mode is only available for heating mode. This mode is set to keep indoor temperature or leaving water temperature in a certain range, so as to prevent water system of the unit from freezing or protect certain indoor articles from freezing damage. When the unit stops due to malfunction, the two e-heaters of the unit will run.

(9) Forced Operation Mode;

Forced Operation Mode: this mode is only used for refrigerant recovery and debugging for the unit.

(10) Quiet mode;

Quiet mode: Silent mode is available in cooling, heating and water heating mode. In silent mode, the unit will reduce the running noise via automatic control.

(11) Disinfection mode;

Disinfection mode: in this mode, the water heating system can be disinfected. When starting up the disinfection function and setting corresponding time to meet the requirement of disinfection mode, the function will start. After the setting temperature is reached, this mode will terminate.

(12) Weather-dependent Operation;

Weather-dependent Operation: this mode is only available for space heating or space cooling. In Weather-dependent mode, the setting value (remote room air temperature or leaving water temperature) is detected and controlled automatically when the outdoor air temperature is changed.

(13) Floor debugging

Floor commissioning: this function is intended to preheat the floor periodically for the initial use.

(14) Air removal of the water system

Air removal of the water system: this function is intended to replenish water and remove air in the water system to make the equipment run at the stabilized water pressure.

(15) Solar water heater

Solar water heater: when the condition for starting the solar water heater is satisfied, the solar heater will start to heat the circulation water. Then the heated water will go to the water tank and exchange heat with water in it. At any condition, the solar water heater will be given priority for startup so as for energy conservation.

(16) Backup heat source

Backup heat source: when the outdoor temperature is lower than the set point for starting the backup heat source and the unit is under the error condition and the compressor has stopped for three minutes, then the backup heat source will start to supply heat or hot water to the room.

3. Nomenclature

ML-	RS	-	C	Q	16	Pd	/	Na	C	-	M
1	2		3	4	5	6		7	8		9

NO.	Description	Options
1	MegaLife	ML-MegaLife Air to water heat pump
2	Heat Pump Water Heater	RS
3	Heating Mode	S= Static; C=Circulating
4	Function	Q=Multi-function; Omit=Single-function
5	Nominal Heating Capacity	6=6.0kW; 8=8.0kW;10=10kW; 12=12kW; 14=14kW; 16=16kW
6	Compressor Style	Pd=DC Inverter; Omit=On/Off
7	Refrigerant	Na=R410A
8	Design Serial Number	B,C,D.....
9	Power Supply	K=220-240V,~,50Hz; M=380-415V,3N~,50Hz

Model Line-Up

Model Name	Capacity		Power supply
	Heating ¹ ,kW	Cooling ² ,kW	
ML-RS-CQ8.0Pd/NaC-K	8.2	8.6	220-240V,~,50Hz
ML-RS-CQ10Pd/NaC-K	9.5	9.8	
ML-RS-CQ12Pd/NaC-M	13.0	13.6	380-415V,3N~,50Hz
ML-RS-CQ14Pd/NaC-M	14.2	14.5	

Notes

¹Capacities and power inputs are based on the following conditions:

Indoor Water Temperature 30°C/35°C, Outdoor Air Temperature 7°C DB/6°C WB;

²Capacities and power inputs are based on the following conditions:

Indoor Water Temperature 23°C/18°C, Outdoor Air Temperature 35°C DB/24°C WB.

Operation Range

Mode	Heat Source Side Temperature (°C)	User Side Temperature (°C)
Heating	-20~35	25~60
Cooling	10~48	7~25
Water Heating	-20~45	40~80

4. Installation Example

CASE 1: Connecting Heat Emitters for Heating and Cooling(Under floor loop,Fan Coil Unit,and Radiator)

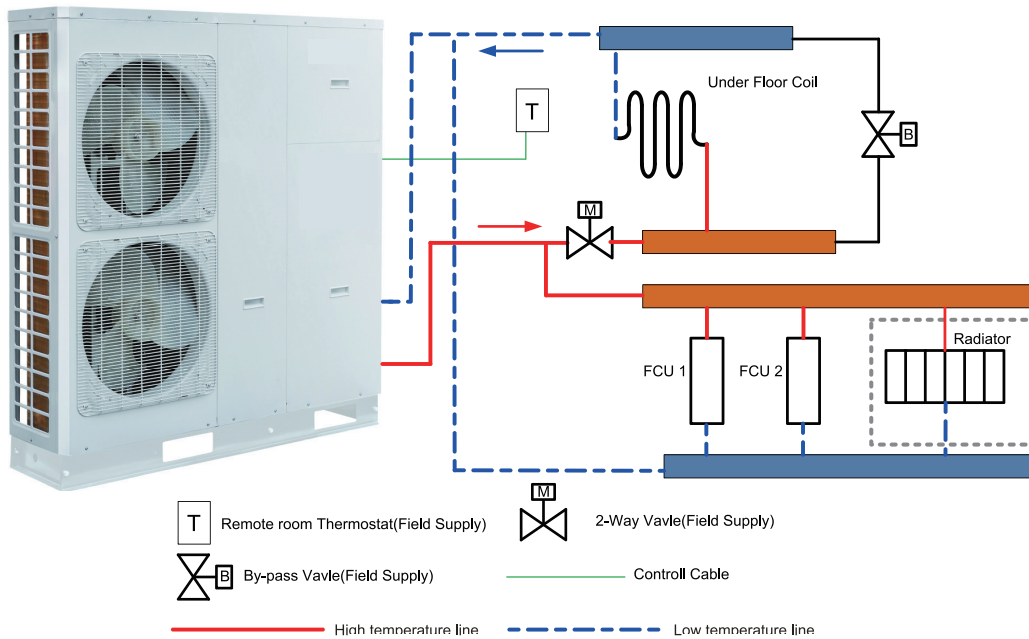

Notes

- (a) The two-way valve is very important to prevent dew condensation on the floor and Radiator while cooling mode;
- (b) Type of thermostat and specification should be complied with installation of this manual;
- (c) The Bypass valve must be installed to secure enough water flow rate, and should be installed at the collector;

CASE 2: Connecting Sanitary Water Tank

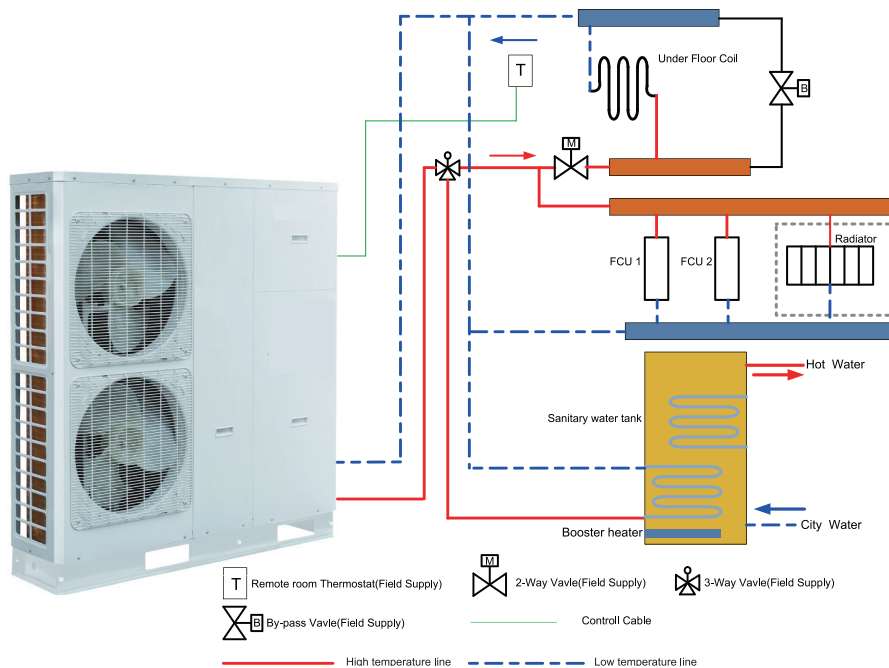

Notes

- (a) In this case, three-way valve should be installed and should be complied with installation of this manual;
- (b) Sanitary water tank should be equipped with internal electric heater to secure enough heat energy in the very cold days;

CASE 3 : Connecting Solar thermal system

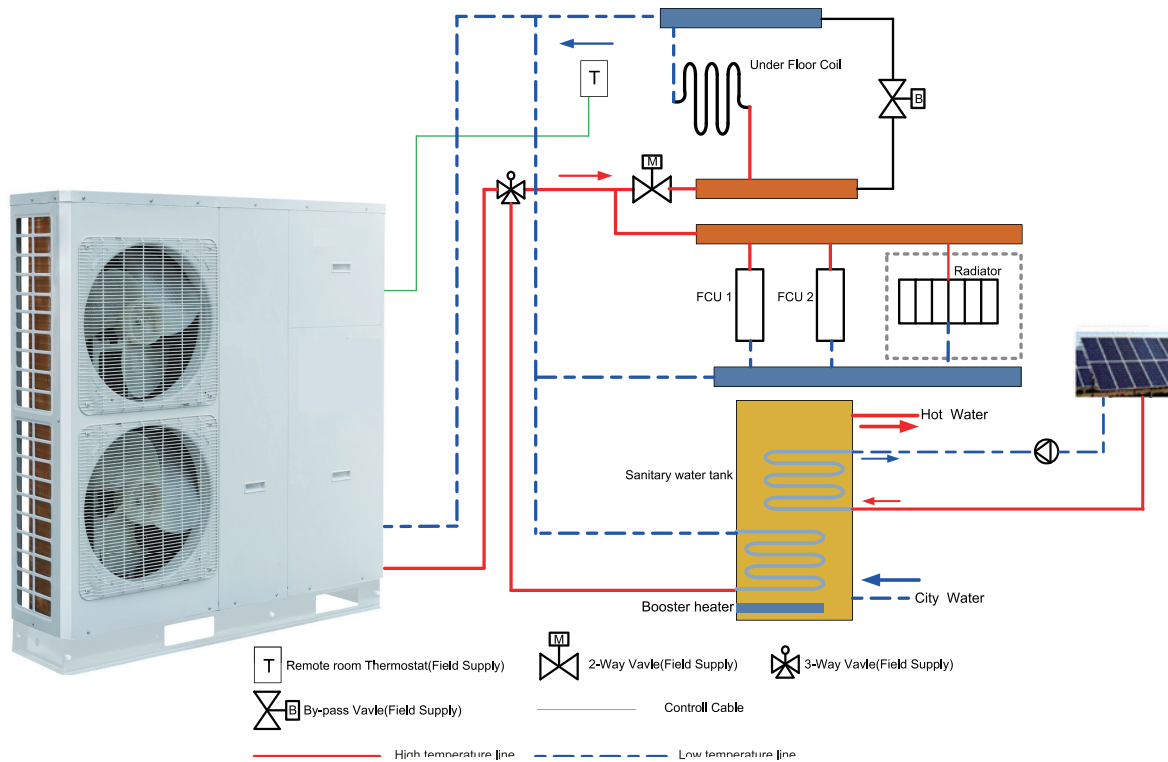

Notes

- (a) Two-way valve is very important to prevent dew condensation on the floor and Radiator while cooling mode.
- (b) 3-Way valve 1 is controlled by user, while the pool pump is activated, 3-Way valve 1 switches to
- (c) pool loop; while the pool pump is shutted down, 3-Way valve 1 switches to under floor/FCU loop.
- (d) 3-Way valve 2 is automatic controlled by monobloc unit, while running water heating mode, 3-Way valve 2 switches to water tank loop; while running cooling/heating mode, 3-Way valve 2 switches to under floor/FCU loop.

5. Main Components

ML-RS-CQ8.0Pd/NaC-K, ML-RS-CQ10Pd/NaC-K

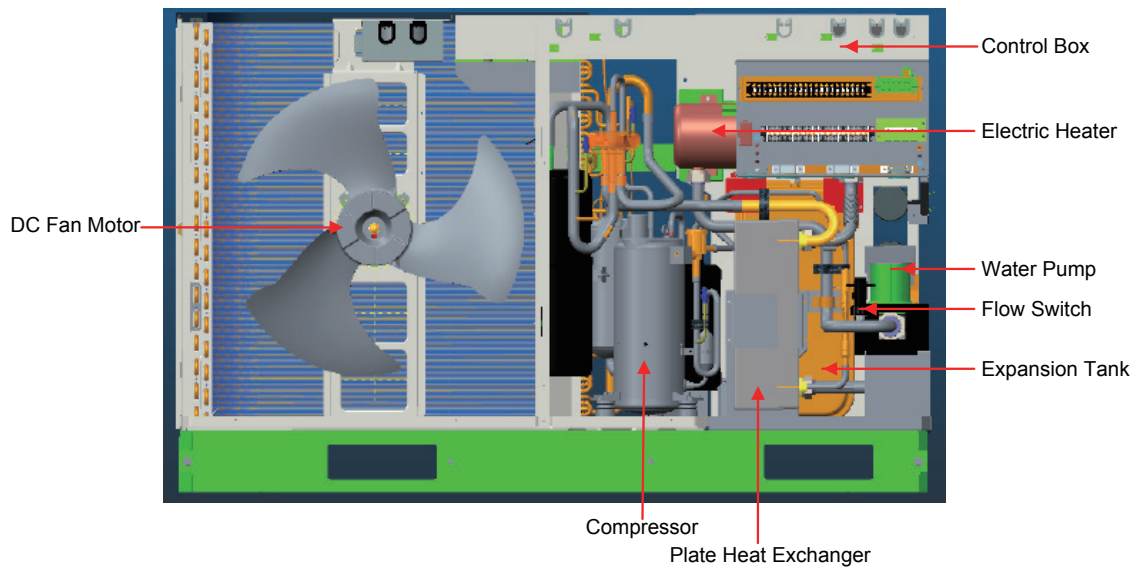

ML-RS-CQ12Pd/NaC-M, ML-RS-CQ14Pd/NaC-M

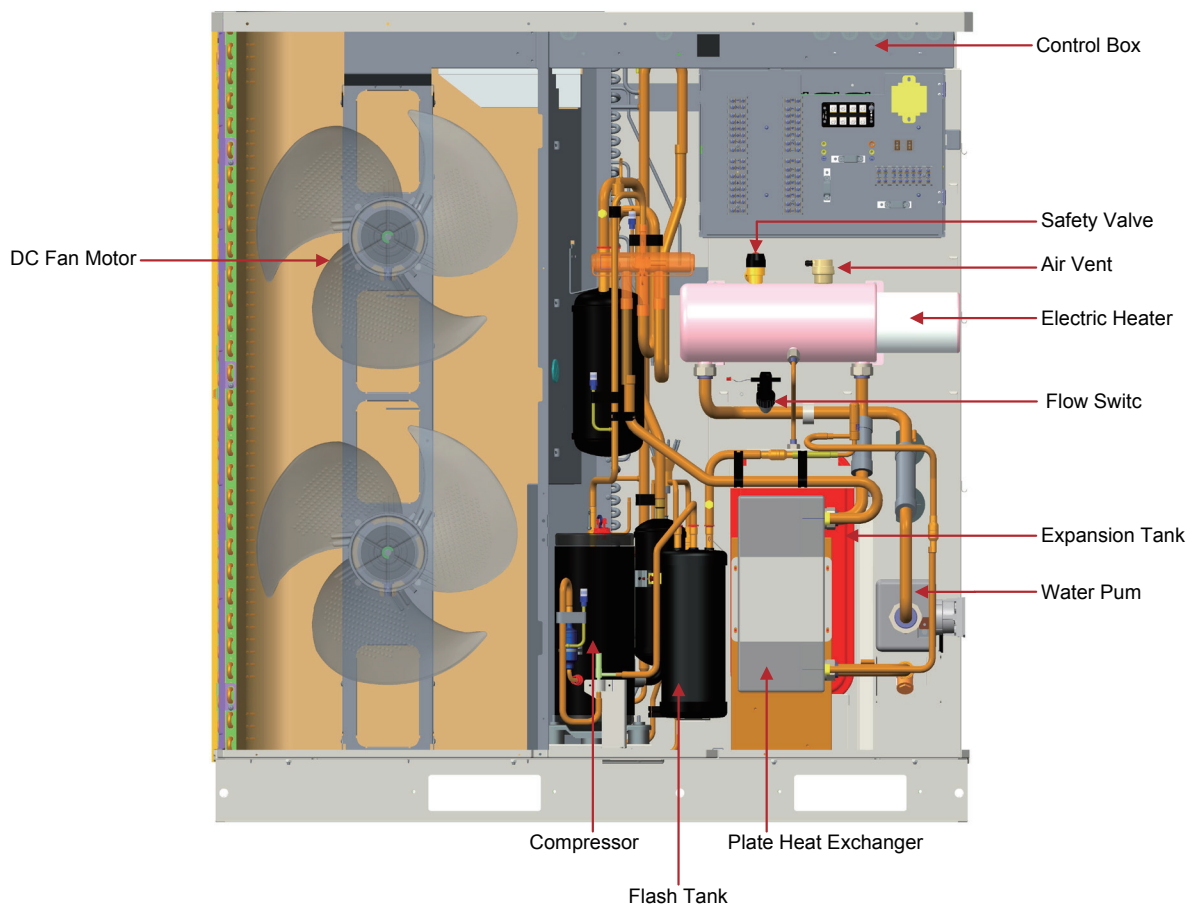

6. Installation Guideline of the Unit

6.1 Instruction to installation

Installation of the unit must be in accordance with national and local safety codes.

Installation quality will directly affect the normal use of the air conditioner unit. The user is prohibited from installation. Please contact your dealer after buying this machine. Professional installation workers will provide installation and test services according to installation manual.

Do not connect to power until all installation work is completed.

6.2 Installation of the Monobloc Unit

6.2.1 Selection of the Installation Location of the Monobloc Unit

The monobloc unit must be installed on a firm and solid support.

Avoid placing the monobloc unit under window or between two constructions, hence to prevent normal operating noise from entering the room.

Air flow at inlet and outlet shall not be blocked.

Install at a well-ventilated place, so that the machine can absorb and discharge sufficient air.

Do not install at a place where flammable or explosive goods exist or a place subject to severe dust, salty fog and polluted air.

6.2.2 Outline Dimensions of the Monobloc Unit

ML-RS-CQ8.0Pd/NaC-K, ML-RS-CQ10Pd/NaC-K

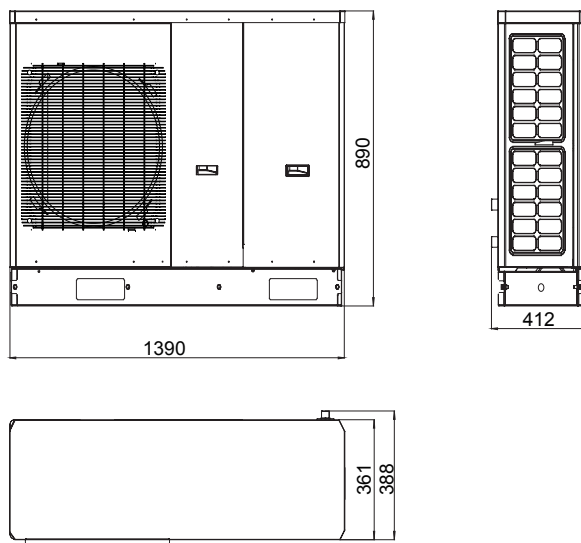

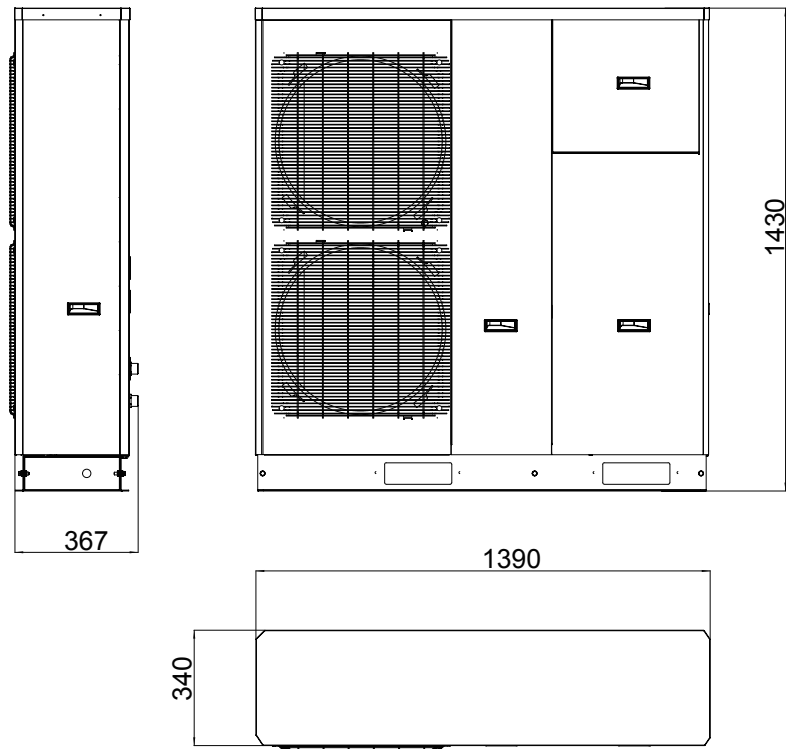

6.2.3 Space requirements for installation

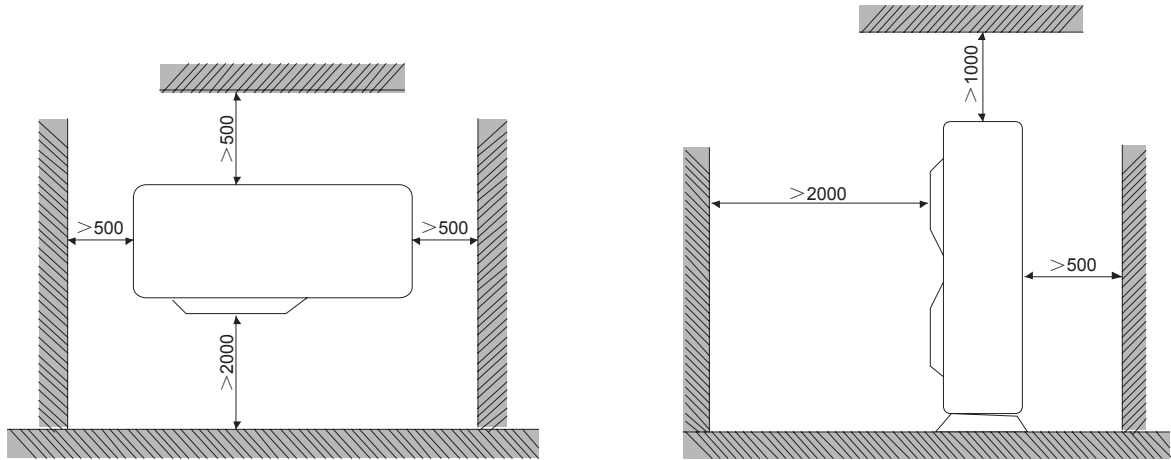

6.2.4 Precautions on installation of the Monobloc Unit

When moving the monobloc unit, it is necessary to adopt 2 pieces of long enough rope to hand the unit from 4 directions. Included angle between the rope when hanging and moving must be 40° below to prevent center of the unit from moving.

The monobloc unit should be installed on concrete base that is 10cm height.

Requirements on installation space dimension of unit's bodies are shown in following drawing.

The monobloc unit must be lifted by using designated lifting hole. Take care to protect the unit during lift. To avoid rusting, do not knock the metal parts.

6.3 Water Volume and Pump Capacity (with pump)

Wilco-Stratos PARA 25/1-11

$\Delta p-c$ (constant)

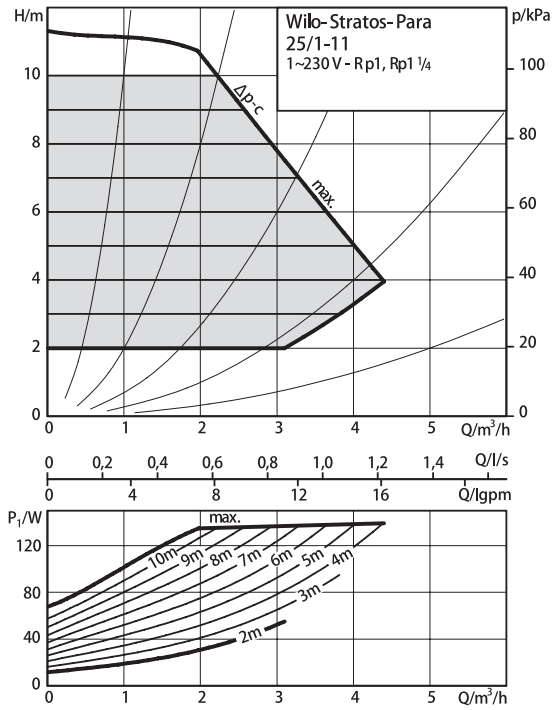

Wilco-Stratos PARA 25/1-11

$\Delta p-v$ (variable)

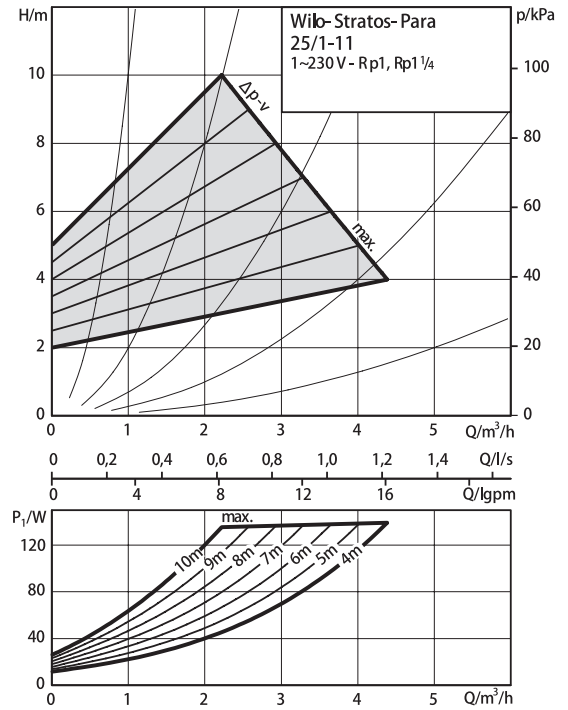

Wilco-Stratos PARA 25/1-11

External control mode via Analog-In 0-10 V

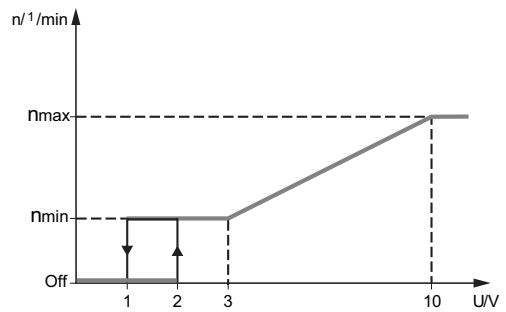
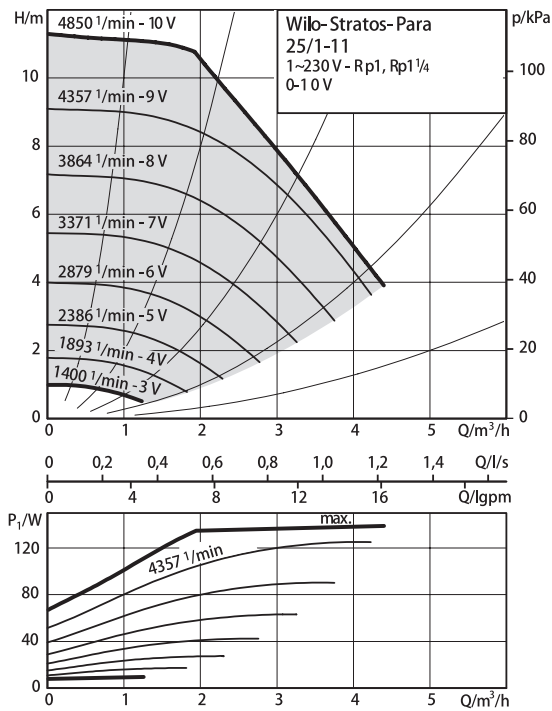

Note

During operation, the water pump will adjust its output based on the actual load.

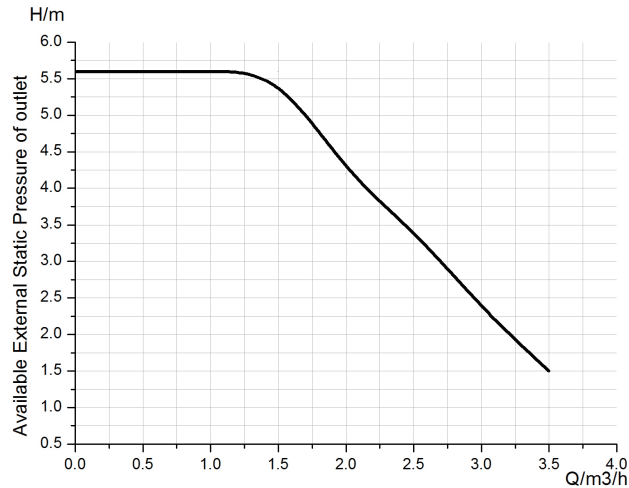

Notes:

- (a) During operation, the water pump will adjust its output based on the actual load.
- (b) Model of the water pump is RS25/7.5.

6.4 Water Volume and Expansion Vessel Pressure

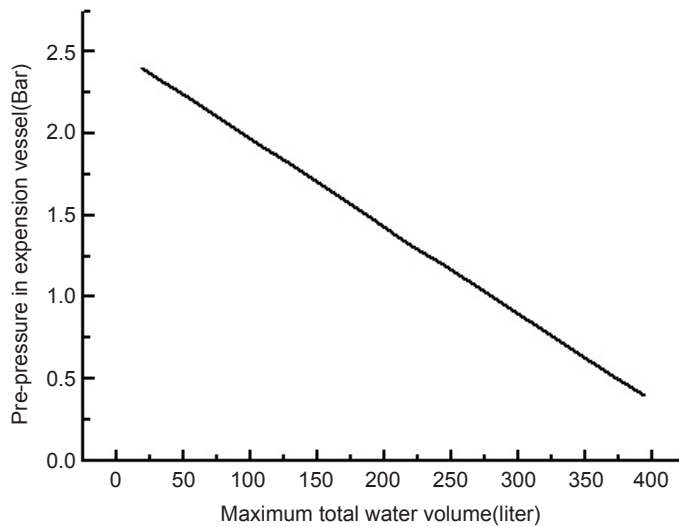

Notes

- (a) The expansion vessel is 10 liter and 1bar pre-pressurized;
- (b) Total water volume of 280 liter is default; if total water is changed because of installation condition, the pre-pressure should be adjusted to secure proper operation;
- (c) Minimum total water volume is 20 liter;
- (d) To adjust pre-pressure, use nitrogen gas by certificated installer.

6.5 Selection of Expansion Vessels

Formula:

$$V = \frac{C \cdot e}{1 - \frac{1 + p_1}{1 + p_2}}$$

V--- Volume of expansion vessel

C--- Total water volume

P₁--- Pre-set pressure of expansion vessel

P₂-- The highest pressure during running of the system (that is the action pressure of safety valve.)

e---The expansion factor of water (the difference between the expansion factor of the original water temperature and that of highest water temperature.)

Water expansion factor in different temperature	
Temperature(°C)	Expansion factor e
0	0.00013
4	0
10	0.00027
20	0.00177
30	0.00435
40	0.00782
45	0.0099
50	0.0121
55	0.0145
60	0.0171
65	0.0198
70	0.0227
75	0.0258
80	0.029
85	0.0324
90	0.0359
95	0.0396
100	0.0434

7. Remote Air Temperature Sensor

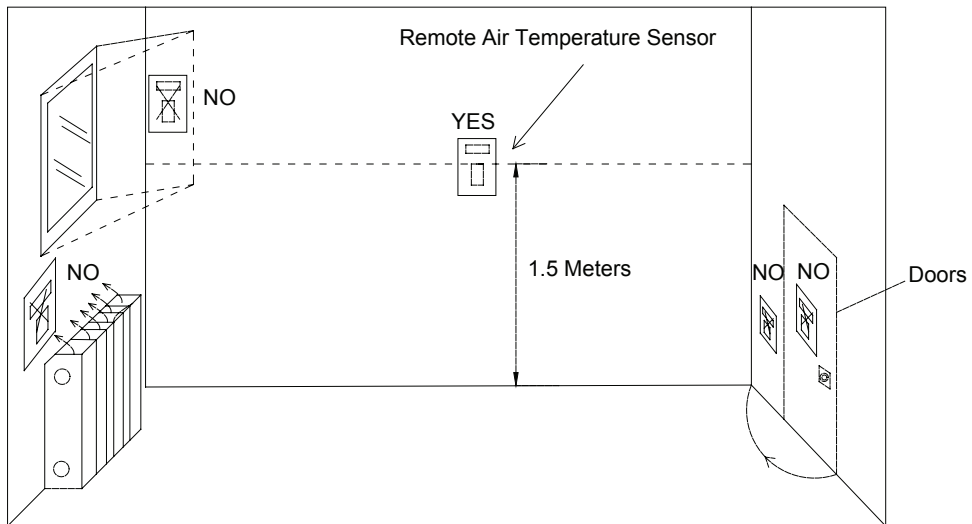
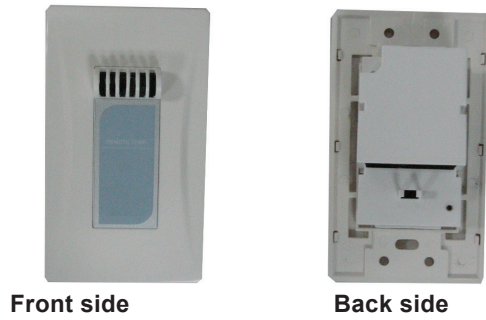

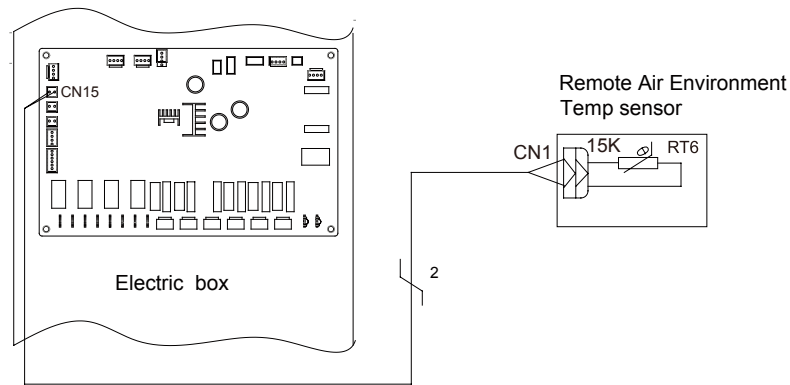

Notes

- (a) Distance between the monobloc unit and the remote air temperature sensor should be less than 15 meter due to length of the connection cable of remote air temperature sensor;
- (b) Height from floor is approximately 1.5 meter;
- (c) Remote air temperature sensor can not be located where the area may be hidden when door is open;
- (d) Remote air temperature sensor can not be located where external thermal influence may be applied;
- (e) Remote air temperature sensor should be installed where space heating is mainly applied;
- (f) After the remote air temperature sensor is installed, it should be set to "With" through the wired controller so as to set the remote air temperature to the control point.

8. Thermostat

Installation of the thermostat is very similar to that of the remote air temperature sensor.

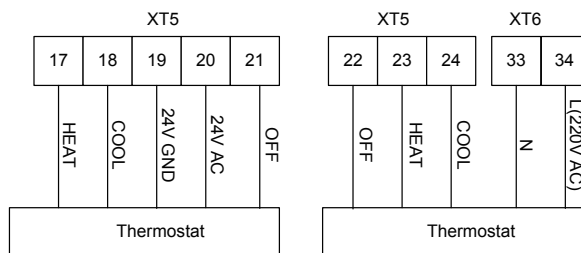

How to Wire Thermostat

Uncover the front cover of the monobloc unit and open the control box.

Identify the power specification of the thermostat, if it is 230V, find terminal block XT5 as NO.22~24 and block XT6 as NO.33~34; Otherwise, if it is 24V, find terminal block XT5 as NO.17~21.

If it is the heating/cooling thermostat, please connect wire as per the figure above.

⚠ CAUTION

- Never use 230V AC and 24V AC thermostat at the same time, otherwise, it will cause short circuit and power cut-off by the circuit breaker;
- Setting temperature by the thermostat(heating or cooling) should be within the temperature range of the product ;
- For other constrains, please refer to previous pages about the remote air temperature sensor;
- Do not connect external electric loads. Wire 220V AC(24V AC) and 220V GND(24V GND) should be used only for the electric thermostat.
- Never connect external electric loads such as valves, fan coil units, etc. If connected, the mainboard of the unit can be seriously damaged.
- Installation of the thermostat is very similar to that of the remote air temperature sensor.

9. 2-Way Valve

The 2-way valve 1 is required to control water flow for cooling operation. The role of 2-way valve 1 is to cut off water flow into the underfloor loop when the fan coil unit is equipped for cooling operation.

General Information

Type	Power	Operating Mode	Supported
NO 2-wire	230V 50Hz ~AC	Closing water flow	Yes
		Opening water flow	Yes
NC 2-wire	230V 50Hz ~AC	Closing water flow	Yes
		Opening water flow	Yes

Normal Open type. When electric power is NOT supplied, the valve is open. (When electric power is supplied, the valve is closed.)

Normal Closed type. When electric power is NOT supplied, the valve is closed. (When electric power is supplied, the valve is open.)

How to Wire 2-Way Valve:

Follow steps below to wire the 2-way valve.

Step 1. Uncover the front cover of the unit and open the control box.

Step 2. Find the terminal block and connect wires as below.

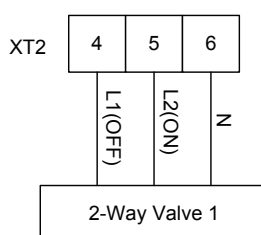

WARNING

- Normal Open type should be connected to wire (ON) and wire (N) for valve closing in cooling mode.
- Normal Closed type should be connected to wire (OFF) and wire (N) for valve closing in cooling mode.
- (ON) : Line signal (for Normal Open type) from PCB to 2-way valve
- (OFF) : Line signal (for Normal Closed type) from PCB to 2-way valve
- (N) : Neutral signal from PCB to 2-way valve

10. 3-Way Valve

The 3-way valve 2 is required for the sanitary water tank. Its role is flow switching between the under floor heating loop and the water tank heating loop.

General Information

Type	Power	Operating Mode	Supported
SPDT 3-wire	230V 50Hz ~AC	Selecting "Flow A" between "Flow A" and "Flow B"	Yes
		Selecting "Flow B" between "Flow B" and "Flow A"	Yes

SPDT = Single Pole Double Throw. Three wires consist of Live1 (for selecting (for selecting Flow B), and Neutral (for common).

Flow A means 'water flow from the monobloc unit to under floor water circuit'.

Flow B means 'water flow from the monobloc unit to sanitary water tank'.

Follow steps below to wire the 3-way valve:

Follow below procedures Step 1 ~ Step 2.

Step 1. Uncover front cover of the unit and open the control box.

Step 2. Find terminal block and connect wire as below.

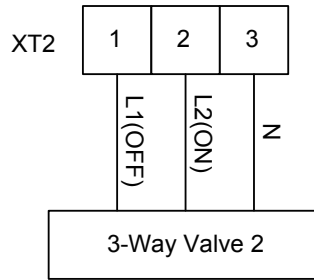

⚠ WARNING

- The 3-way valve should select water tank loop when electric power is supplied to wire (OFF) and wire (N).
- The 3-way valve should select under floor loop when electric power is supplied to wire (ON) and wire (N).
- (ON): Line signal (Water tank heating) from the main board to the 3-way valve
- (OFF): Line signal (Under floor heating) from the main board to the 3-way valve
- (N): Neutral signal from the main board to the 3-way valve

11. Wired Controller

Wired controller wiring guidance:

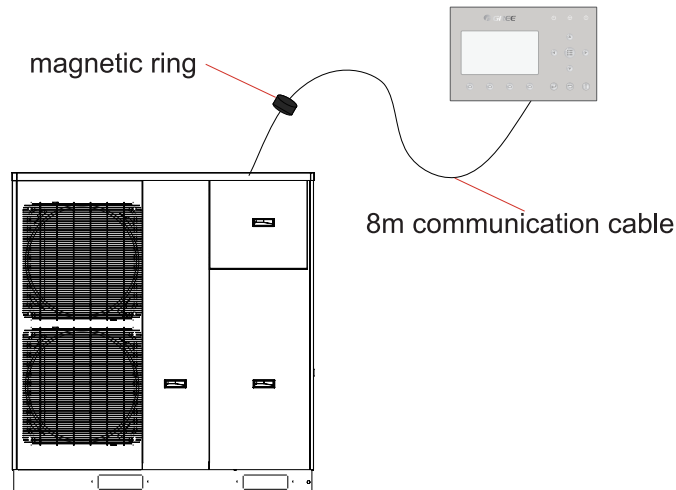

12. Other Auxiliary Heat Sources

Other auxiliary heat sources are allowed for the equipment and controlled in such a way that the mainboard will output 230V when outdoor temperature is lower than the set point for startup of the auxiliary heat source.

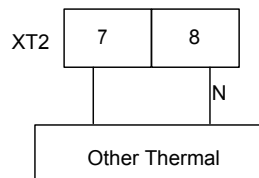

13. Gate-controller

If there is gate control function, installation guide follow as:

ML-RS-CQ8.0Pd/NaC-K, ML-RS-CQ10Pd/NaC-K

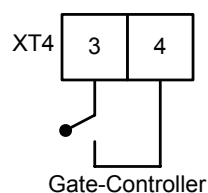

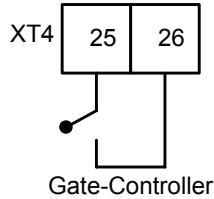

14. Charging and Discharging of Refrigerant

The unit has been charged with refrigerant before delivery. Overcharging or undercharging will cause the compressor to run improperly or be damaged. When refrigerant is required to be charged or discharged for installation, maintenance and other reasons, please follow steps below and nominal charged volume on the nameplate.

Discharging: remove metal sheets of the outer casing, connect a hose to the charging valve and then discharge refrigerant.

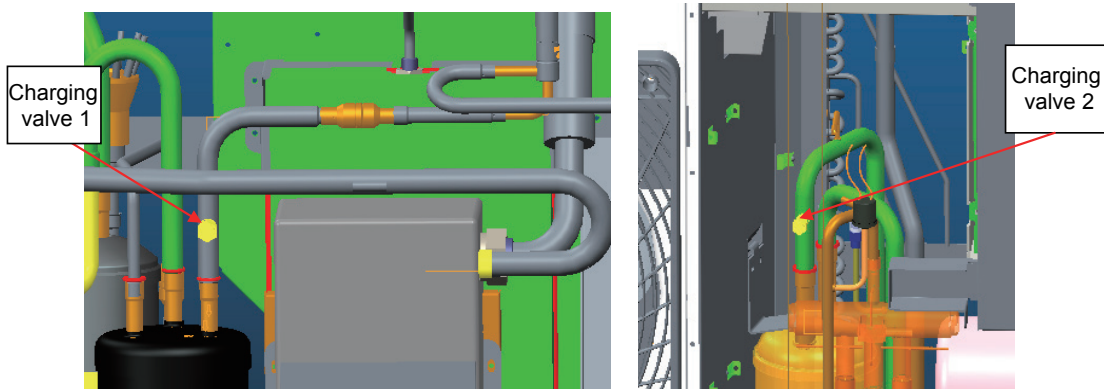

Notes

- (a) Discharge is allowed unless the unit has been stopped. (Cut off the power and repower it 1 minutes later)
- (b) Protective measures should be taken during discharging to avoid frost bites.
- (c) When discharging is finished, if vacuuming cannot be done immediately, remove the hose to avoid air or foreign matters entering the unit.
- (d) Vacuuming: When discharging is finished, use hoses to connect the charging valve, manometer and vacuum pump to vacuum the unit.

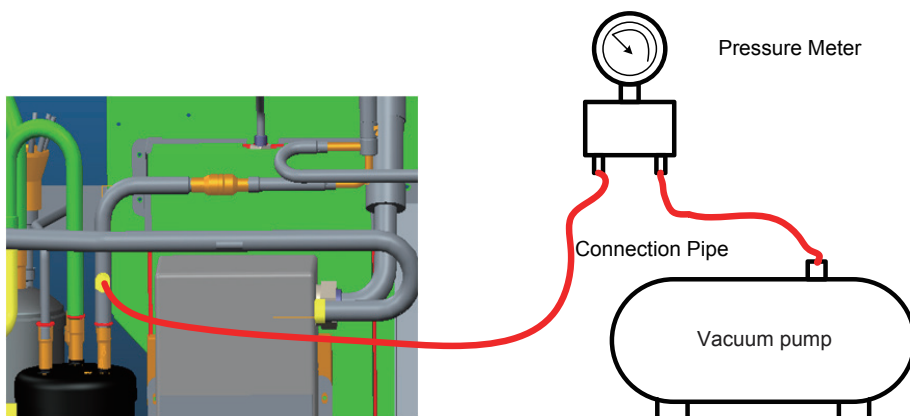

Note

when vacuuming is finished, pressure inside the unit should be kept lower than 80Pa for at least 30 minutes to make sure there is no leak. Either charging valve 1 or charging valve 2 can be used for vacuuming.

Charging: when vacuuming is finished and it is certain that there is no leak, charging can be done.

- (1) Be sure to charge the specified amount of refrigerant in liquid state.
- (2) Since this refrigerant is a mixed refrigerant, adding it in gas form may cause the refrigerant composition to change, preventing normal operation.

(3) Before charging, check whether the refrigerant cylinder is equipped with a siphon tube or not.

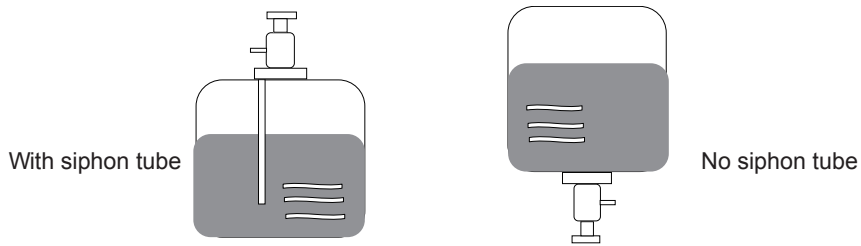

15. Installation of Insulated Water Tank

15.1 Installation measure

The water tank should keep a horizontal distance of 5 meters and a vertical distance of 3 meters with the main unit. It allowed to be installed in the room.

The standing type water tank must be installed erectly on the ground/floor and never be suspended. Installation place must be firm enough and the water tank should be fixed on the wall with bolts to avoid vibration, as shown in the following figure. During installation, weight of the water tank should be taken into consideration.

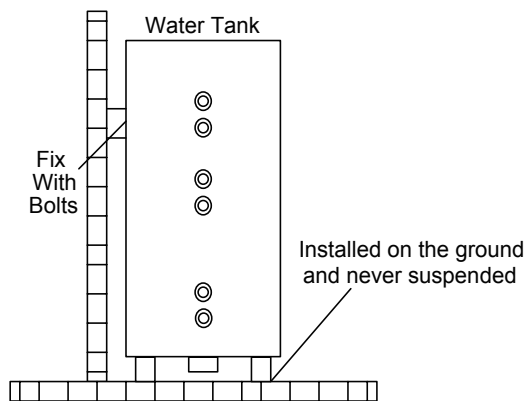

The minimum clearance between the water tank and any combustibile object must be 500mm.

The water pipe, hot water joint and floor drain should be equipped for the water replenishment, hot water supply and drainage of the water tank respectively.

Connection of the inlet/outlet waterway: connect the safety check valve attached with the unit (with the arrow on it pointing at the water tank) to the water inlet of the water tank with the PPR pipe according to the following figure and seal with seal tape. The other end of the safety check valve should connect with the water tap. The hot water pipe should be connected to the water outlet of the water tank also with the PPR pipe.

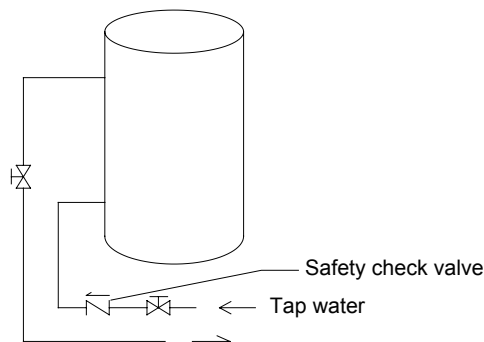

Note

For safe use of water, water outlet/inlet of water tank must connect with a certain length of PPR pipe ,L ≥70×R2(cm, R is inside radius of the pipe). Moreover, heat preservation should be conducted and metal pipe can not be used. For the first use, water tank must be full of water before the power is on.

15.2 Outline dimension and parameter of water tank

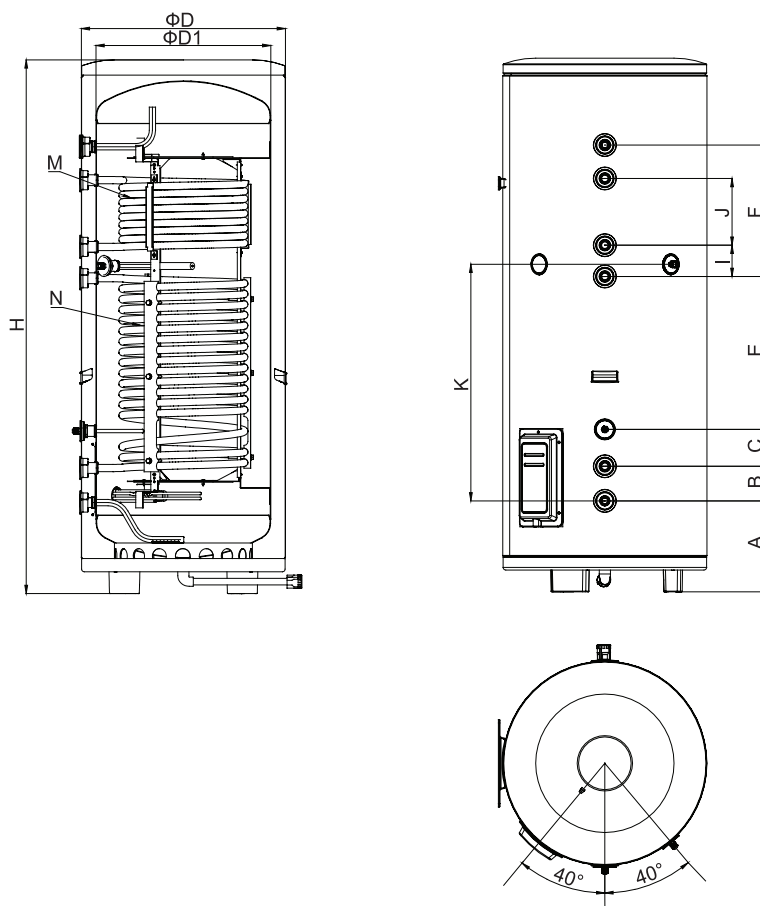

Model	ML-SXVD200LCJ/A-K	ML-SXVD200LCJ2/A-K	ML-SXVD300LCJ/A-K	ML-SXVD300LCJ2/A-K	
	ML-XVD200LCJ/A-M	ML-SXVD200LCJ2/A-M	ML-SXVD300LCJ/A-M	ML-SXVD300LCJ2/A-M	
	ML-SXVD200LCJ/A-H	ML--SXVD200LCJ2/A-H	ML-SXVD300LCJ/A-H	ML-SXVD300LCJ2/A-H	
Litre	200L	200L	300L	300L	
Coil specification	SUS304 $\Phi 22 \times 0.8$				
Coil length	M	\	10m	\	10m
	N	13m	13m	18.5m	18.5m
D(mm)	540		620		
D1(mm)	438		528		
H(mm)	1595		1620		
A(mm)	272		280		
B(mm)	105				
C(mm)	112				
E(mm)	432		464		
F(mm)	431		399		
I(mm)	\	80	\	95	
J(mm)	\	247.5	\	202.5	
K(mm)	739		718		
Outline (Diameter×H) (mm)	$\Phi 540 \times 1595$		$\Phi 620 \times 1620$		
Net weight(kg)	68	71	82	87	

Joins Dimension

Description	Joint pipe thread
Hot water outlet of water tank	1/2"Female BSP
Circulating water inlet/outlet of water tank	3/4"Female BSP
Cooling water inlet of water tank	1/2"Female BSP
Pipe joint	3/4"Female BSP

15.3 Connection of waterway system

If connection between the water tank and the monobloc unit should go through the wall, drill a hole $\phi 70$ for pass of circulating water pipe.

Preparation of pipelines: circulating water outlet/inlet pipe must be hot water pipe and PPR pipe with nominal outer diameter of dn25 and S2.5 series (wall thickness of 4.2mm) are recommended. Cooling water inlet pipe and hot water outlet pipe of water tank should also be hot water pipe and PPR pipe with nominal outer diameter of dn20 and S2.5 series (wall thickness of 3.4mm) are recommended. If other insulated pipes are adopted, refer to the above dimensions for outer diameter and wall thickness.

Installation of circulating water inlet/outlet pipes: connect the water inlet of the unit with circulating outlet of water tank and water outlet of unit with circulating inlet of water tank.

Installation of water inlet/outlet pipes of the water tank: safety check valve, filter and cut-off valve must be installed for the water inlet pipe according to the installation sketch of the unit. At least a cut-off valve is needed for the water outlet pipe.

Installation of blow-off pipes at the bottom of water tank: connect a piece of PPR pipe with drainage outlet to floor drain. A cut-off valve must be installed in the middle of the drainage pipe and at the place where it is easy to be operated by the users.

After connection of all waterway pipelines, perform the leakage test firstly. After that, bind up the water pipes, water temp sensor and wires with wrapping tapes attached with the unit.

Refer to Installation Sketch of the Unit for details.

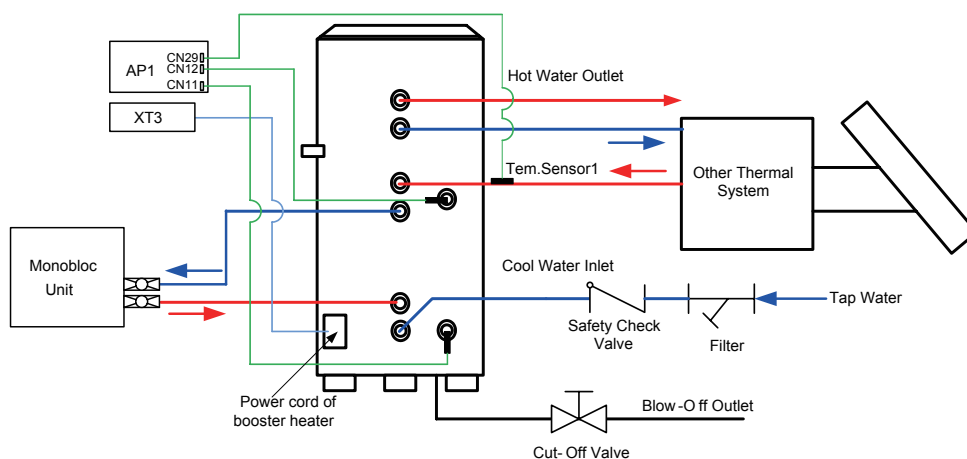

Description	Joint pipe thread
Circulating water inlet/outlet of main unit	1"Male BSP
Cooling water inlet of water tank	1/2"Female BSP
Circulating water inlet/outlet of water tank	3/4"Female BSP
Hot water outlet of water tank	1/2"Female BSP

Notes

- Distance between monobloc unit and water tank should not exceed 5m levelly and 3m vertically. If higher, please contact with us. Water tank on lower and main unit on higher side is recommended.
- Prepare the materials according to the above joints dimension. If cut-off valve is installed outside the room, PPR pipe is recommended to avoid freeze damage.
- Waterway pipelines can't be installed until water heater unit is fixed. Do not let dust and other sundries enter into pipeline system during installation of connection pipes.
- After connection of all waterway pipelines, perform leakage test firstly. After that, perform heat preservation of waterway system; meanwhile, pay more attention to valves and pipe joints. Ensure enough thickness of insulated cotton. If necessary, install heating device for pipeline to prevent the pipeline from freezing.
- Hot water supplied from insulated water tank depends on pressure of water tap, so there must be supply of tap water.
- During using, the cut-off valve of cooling water inlet of water tank should be kept normally on.

15.4 Electric wiring work

15.4.1 Wiring principle

General principles

- (1) Wires, equipment and connectors supplied for use on the site must be in compliance with provisions of regulations and engineering requirements.
- (2) Only certificated electricians are allowed to perform wire connection on the site.
- (3) Before connection work is started, the power supply must be shut off.
- (4) Installer shall be responsible for any damage due to incorrect connection of the external circuit of the unit.
- (5) Caution --- only copper wires are allowed to be used.

Connection of power cable to the electric cabinet of the unit

- (1) Power cables should be laid out through cabling trough, conduit tube or cable channel.
- (2) Power cables to be connected into the electric cabinet must be protected with rubber or plastic to prevent scratch by edge of metal plate.
- (3) Power cables close to the electric cabinet of the unit must be fixed reliably to make the power terminal in the cabinet free from an external force.
- (4) Power cable must be grounded reliably.

15.4.2 Specification of Power Supply Wire and Leakage Switch

Power cable specifications and Leakage switch types in the following list are recommended.

Model	Power Supply	Leakage Switch	Minimum Sectional Area of Earth Wire	Minimum Sectional Area of Power Supply Wire
	V,Ph,Hz	(A)	(mm ²)	(mm ²)
ML-RS-CQ8.0Pd/NaC-K	220-240V,~,50Hz	63	16	5×16
ML-RS-CQ10Pd/NaC-K		63	16	5×16
ML-RS-CQ12Pd/NaC-M	380-415V,3N~,50Hz	40	10	5×10
ML-RS-CQ14Pd/NaC-M		40	10	5×10

Notes

- (a) The leakage switch is necessary for additional installation. If circuit breakers with leakage protection are in use, action response time must be less than 0.1 second, leakage circuit must be 30mA.
- (b) The above selected power cable diameters are determined based on assumption of distance from the distribution cabinet to the unit less than 75m. If cables are laid out in a distance of 75m to 150m, diameter of power cable must be increased to a further grade.
- (c) The power supply must be of rated voltage of the unit and special electrical line for air-conditioning.
- (d) All electrical installation shall be carried out by professional technicians in accordance with the local laws and regulations.
- (e) Ensure safe grounding and the grounding wire shall be connected with the special grounding equipment of the building and must be installed by professional technicians.
- (f) The specifications of the breaker and power cable listed in the table above are determined based on the maximum power (maximum amps) of the unit.
- (g) The specifications of the power cable listed in the table above are applied to the conduit-guarded multi-wire copper cable (like, YJV XLPE insulated power cable) used at 40°C and resistible to 90°C(see IEC 60364-5-52). If the working condition changes, they should be modified according to the related national standard.
- (h) The specifications of the breaker listed in the table above are applied to the breaker with the working temperature at 40°C. If the working condition changes, they should be modified according to the related national standard.

16. Wring Diagram

16.1 Control Board

(1) Main Board (AP2):ML-RS-CQ8.0Pd/NaC-K, ML-RS-CQ10Pd/NaC-K, ML-RS-CQ12Pd/NaC-M, ML-RS-CQ14Pd/NaC-M

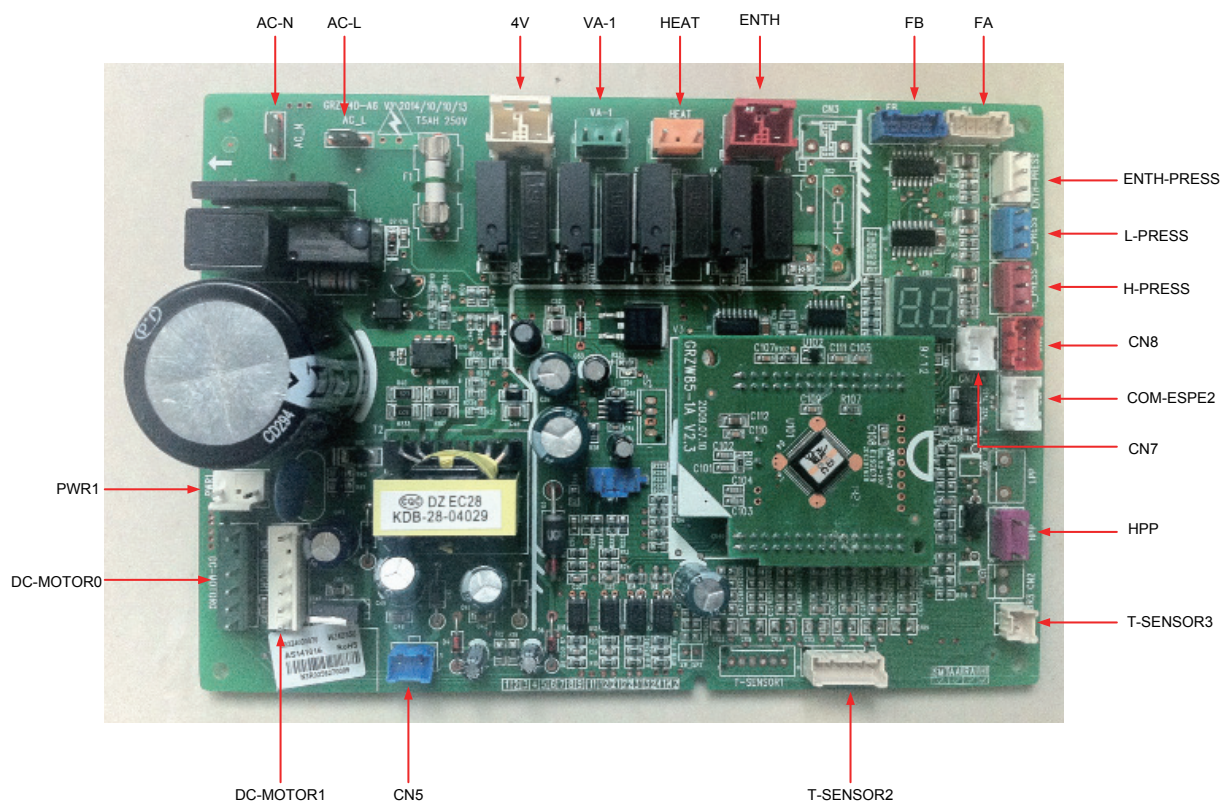

Silk Screen	Specification
AC_N	Neutral wire input of power supply
AC_L	Live wire input of power supply
4V	4-way valve
VA-1	E-heater of chassis
HEAT	Electric heating tape
ENTH	Solenoid valve
FB	To EXV2,pipe electric expansion valve,1-4 pin: driving impulse output; 5 pin: +12V;
FA	To EXV1,pipe electric expansion valve,1-4 pin: driving impulse output; 5 pin: +12V;
ENTH-PRESS	Signal input of pressure sensor 1 pin: GND; 2 pin: signal input; 3 pin: +5V;
L-PRESS	Signal input of pressure sensor 1 pin: GND; 2 pin: signal input; 3 pin: +5V;
H-PRESS	Signal input of pressure sensor 1 pin: GND; 2 pin: signal input; 3 pin: +5V;
CN8	To the wired controller, communication cable: 1 pin earthed, 2 pin B, 3 pin A, 4 pin+12power supply;
CN7	Communication between AP1 and AP2;communication cable 2 pin B, 3 pinA
COM-ESPE2	Pin for communication with the drive
HPP	High pressure switch
T-SENSOR3	1 hole: +3.3V 2 hole: detection ; suction temperature sensor
T-SENSOR2	1, 2 hole: pipe temperature; 3, 4 hole: environment; 5, 6 hole: exhaust
CN5	Supply 18V DC power to the drive.
DC-MOTOR1	DC fan 1 pin: strong power supply; 3 pin: fan GND; 4 pin: +15V; 5 pin: control signal; 6pin:feedback signal;
DC-MOTOR0	DC fan 1 pin: strong power supply; 3 pin: fan GND; 4 pin: +15V; 5 pin: control signal; 6pin:feedback signal;
PWR1	Supply 310V DC power to the drive.

(2) Main Board (AP1):ML-RS-CQ8.0Pd/NaC-K, ML-RS-CQ10Pd/NaC-K, ML-RS-CQ12Pd/NaC-M, ML-RS-CQ14Pd/NaC-M

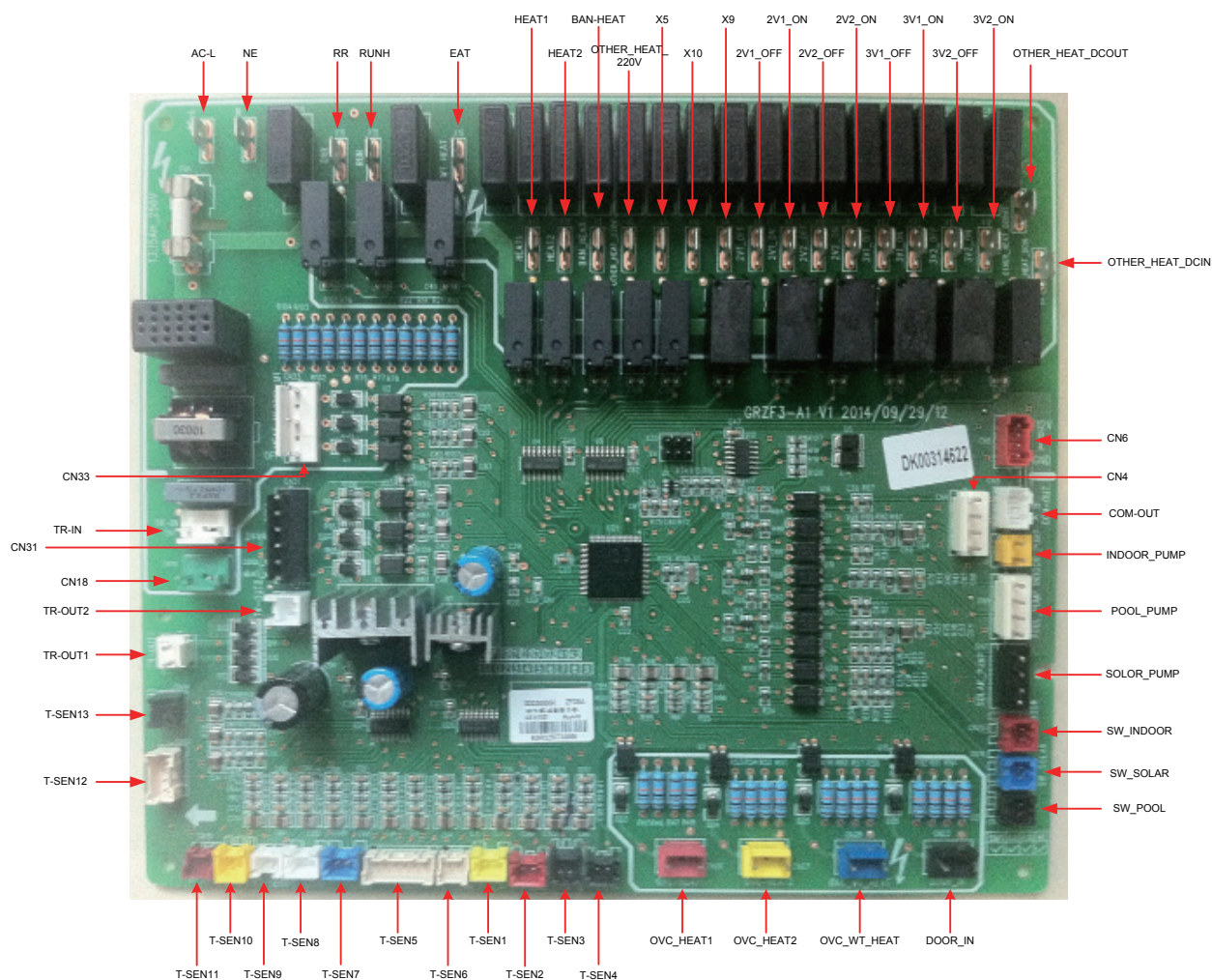

Silk Screen	Location	Introduction
AC-L	-	Live wire of power supply
N	-	Neutral wire of power supply
ERR	X19	Error indicator
RUN	X15	Running indicator
WT_HEAT	X16	E-heater of water tank
HEAT1	X17	E-heater 1
HEAT2	X18	E-heater 2
BAN_HEAT	X3	Antifreeze heater for the heat exchanger
OTHER_HEAT_220V	X6	Assistant heat by 220VAC
X5	X5	Reserved
X10	X10	Reserved
X9	X9	Reserved
2V1_OFF	X8	Electric magnetic 2-way valve1 is normally closed.
2V1_ON	X7	Electric magnetic 2-way valve1 is normally open.
3V2_OFF	X11	Electric magnetic 3-way valve2 is normally closed.
3V2_ON	X12	Electric magnetic 3-way valve2 is normally open.

OTHER_HEAT_DCOUT	X1	The dc output of assistant heat
OTHER_HEAT_DCIN	X2	The dc input of assistant heat
COM-OUT	CN5	Connect to AP2
CN6	CN6	Connect the wired controller
INDOR_PUMP	CN4	Control and feedback of the water pump for the main unit
CN8	CN8	Feedback of the water pump for the main unit
SOLAR_PUMP	CN7	Control and feedback of the water pump for the solar system
SW_INDOOR	CN25	Detection input of water flow switch for indoor
SW_SOLAR	CN16	Detection input of water flow switch for solar
SW_POOL	CN17	Detection input of water flow switch for pool
DOOR_IN	CN23	Door detection input
OVC_WT_HEAT	CN28	E-heater of water tank adhesion-proof protection detector
OVC-HEAT1	CN26	E-heater of indoor unit1 adhesion-proof protection detector
OVC-HEAT2	CN27	E-heater of indoor unit2 adhesion-proof protection detector
T-SEN4	CN20	Terminal of temperature sensor4
T-SEN3	CN22	Terminal of temperature sensor3
T-SEN2	CN21	Terminal of temperature sensor2
T-SEN1	CN11	Terminal of temperature sensor1
T-SEN6	CN12	Terminal of temperature sensor6
T-SEN5	CN10	Terminal of temperature sensor5
T-SEN7	CN29	Terminal of temperature sensor7
T-SEN8	CN32	Terminal of temperature sensor8
T-SEN9	CN30	Terminal of temperature sensor9
T-SEN10	CN24	Terminal of temperature sensor10
T-SEN11	CN15	Terminal of temperature sensor11
T-SEN12	CN13	Terminal of temperature sensor12
T-SEN13	CN14	Terminal of temperature sensor13
TR-OUT1	CN2	Transformer output 1 (12V)
TR-OUT2	CN3	Transformer output 2 (24V)
CN18	CN18	Power supply interface of the thermostat (220~240V)
TR-IN	CN1	220V input of transformer
CN31	CN31	Power supply interface and control signal of the thermostat (24V)
CN33	CN33	Control signal of the thermostat

(3) Drive Board (AP4): ML-RS-CQ8.0Pd/NaC-K, ML-RS-CQ10Pd/NaC-K

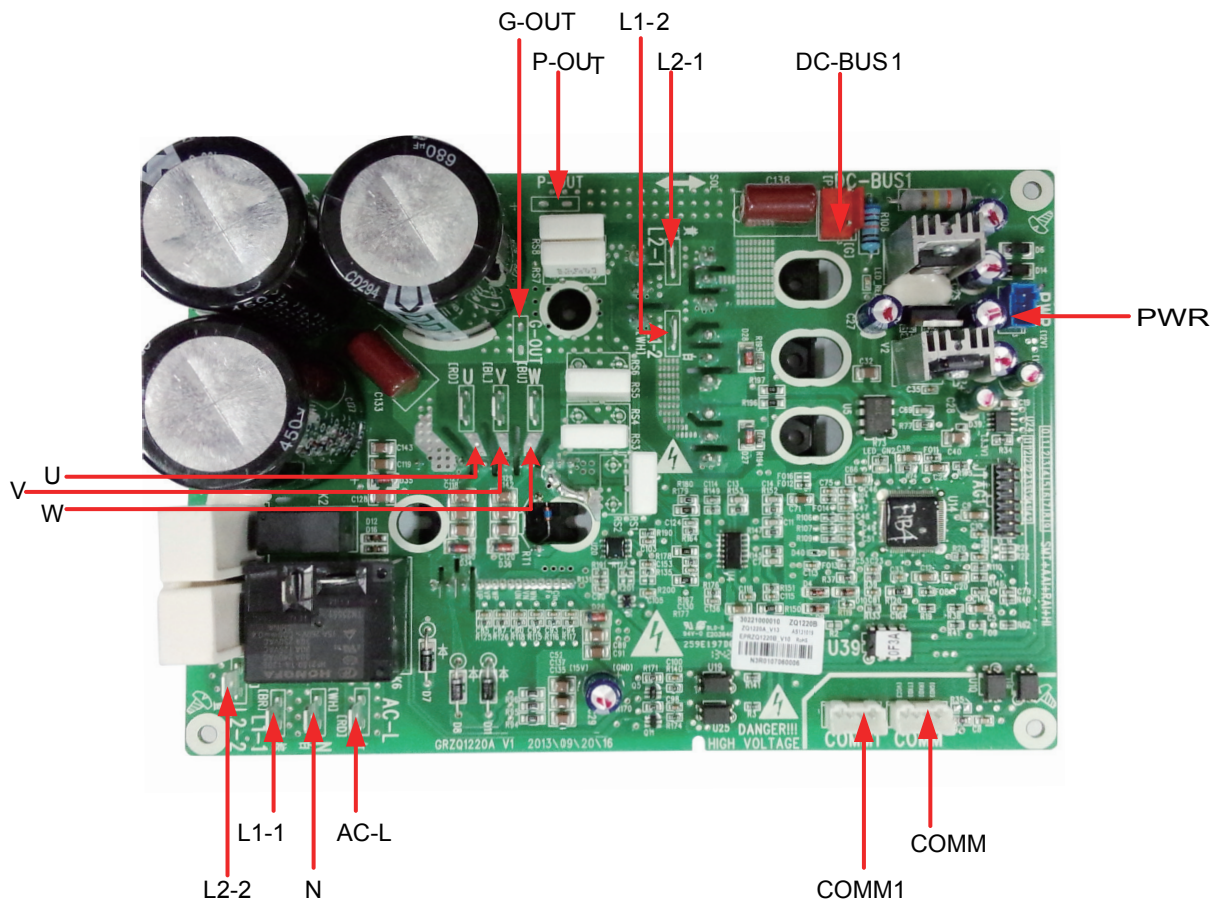

Silk Screen	Introduction
AC-L	Live line input of the drive board
N	Neutral line input of the drive board
L1-1	To PFC inductor brown line
L1-2	To PFC inductor white line
L2-1	To PFC inductor white line
L2-2	To PFC inductor blue line
U	To compressor phase U
V	To compressor phase V
W	To compressor phase W
DC-BUS1	Pin for electric discharge of the high-voltage bar during test.
P-OUT	Reserved
G-OUT	Reserved
COMM COMM1	Communication interface[1-3.3V,2-TX,3-RX,4-GND]
PWR	Power input of the drive board [1-GND,2-18V,3-15V]

(4) Drive Board (AP4): ML-RS-CQ12Pd/NaC-M, ML-RS-CQ14Pd/NaC-M

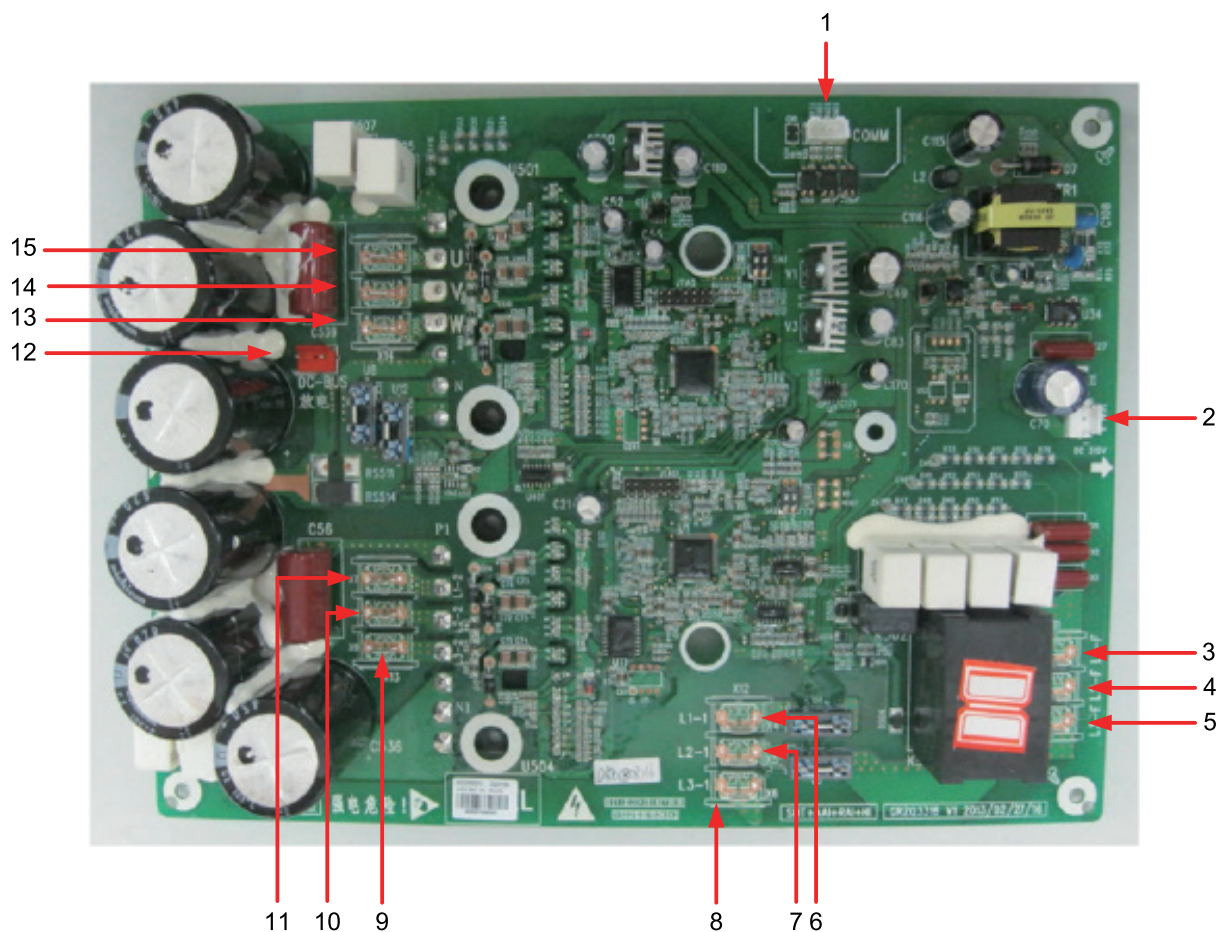

No	Silk Screen	Introduction
1	COMM	Communication interface [1-3.3V, 2-TX, 3-RX, 4-GND]
2	PWR	Switch power interface [1-310VDC, 3-GND]
3	X1	Connector to filter L1-F
4	X2	Connector to filter L2-F
5	X3	Connector to filter L3-F
6	X4	Connector to L1-1 OF PFC reactor 1
7	X5	Connector to L2-1 OF PFC reactor 2
8	X6	Connector to L3-1 OF PFC reactor 3
9	X9	Connector to L3-2 of PFC reactor 3
10	X8	Connector to L2-2 of PFC reactor 2
11	X7	Connector to L1-2 of PFC reactor 1
12	DC-BUS	Pin for electric discharge of the high-voltage bar during test.
13	X501	Connector to the compressor phase-U
14	X502	Connector to the compressor phase-V
15	X503	Connector to the compressor phase-W

(5) Filter Board (AP3): ML-RS-CQ8.0Pd/NaC-K, ML-RS-CQ10Pd/NaC-K



Silk Screen	Introduction
AC-N	Neutral line of the power supply for the main unit
AC-L	Live line of the power supply for the main unit
N-OUT	Neutral line output of the filter board (to the drive board)
	Neutral line output of the filter board (to the main board)
N-OUT1	Reserved
L-OUT	Live line output of the filter board (to the drive and main boards)
E1	To the grounding line of the main unit
E2	Reserved

(6) Filter Board (AP3): ML-RS-CQ12Pd/NaC-M, ML-RS-CQ14Pd/NaC-M

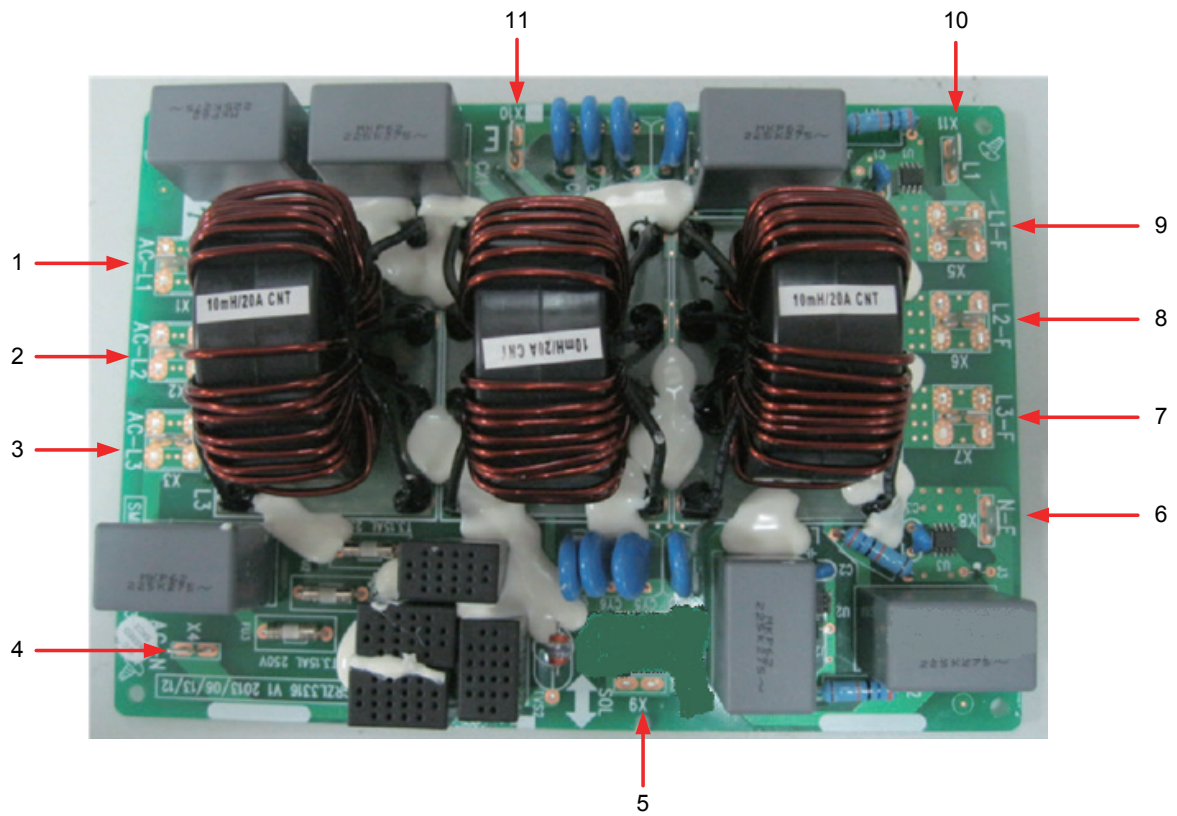

No	Silk Screen	Introduction
1	X1	Connector to power supply output line AC-L1
2	X2	Connector to power supply output line AC-L2
3	X3	Connector to power supply output line AC-L3
4	X4	Connector to power supply neutral line AC-N
5	X9	Connector to the grounding line E , reserved
6	X8	Connector to power supply neutral line N-F (mainboard AC-N)
7	X7	Connector to power supply output line L3-F (drive board L3-F)
8	X6	Connector to power supply output line L2-F (drive board L2-F)
9	X5	Connector to power supply output line L1-F (drive board L1-F and AC-L)
10	X11	Connector to power supply output line L1-F (drive board L1-F and AC-L)
11	X10	Connector to the grounding line E

16.2 Electric Wiring

16.2.1 Wiring principle

Refer to Section 16.4.

◆ Electric wiring design

The electric wiring diagram stuck to the unit always prevails.

Wiring diagram: monobloc unit.

(1) ML-RS-CQ8.0Pd/NaC-K, ML-RS-CQ10Pd/NaC-K

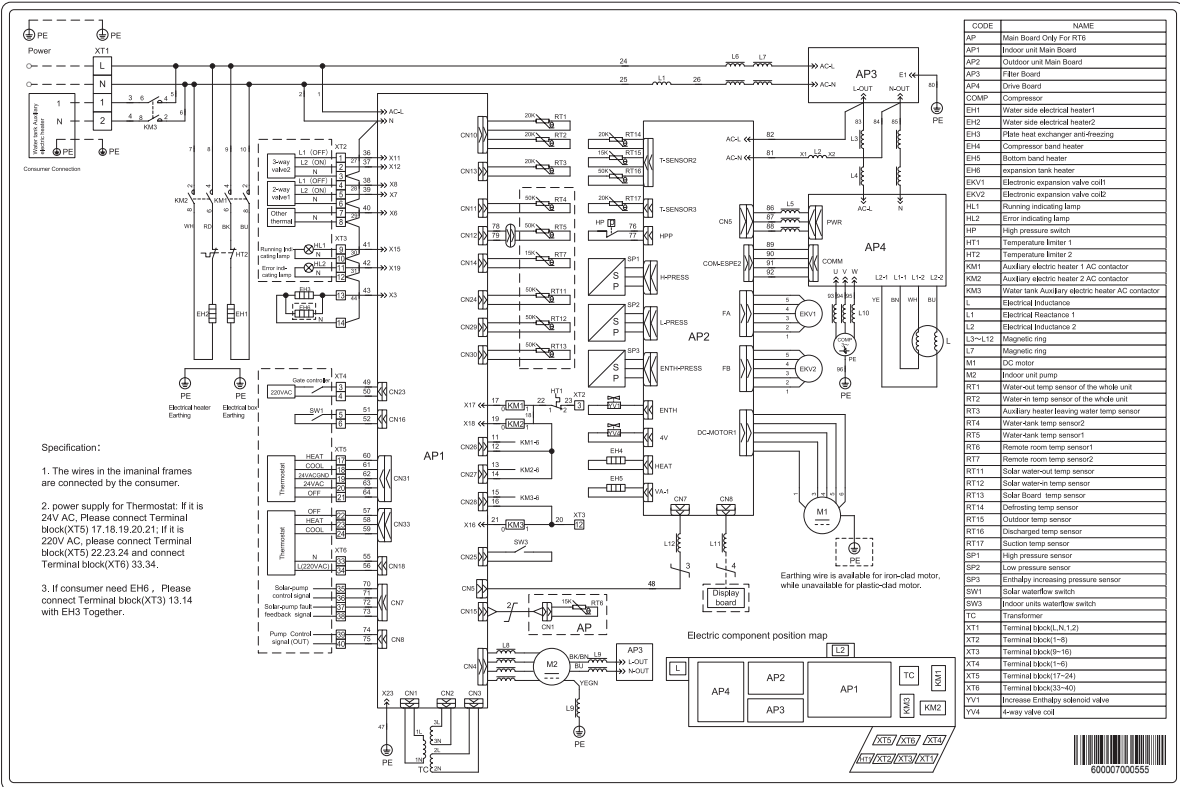

(2) ML-RS-CQ12Pd/NaC-M, ML-RS-CQ14Pd/NaC-M

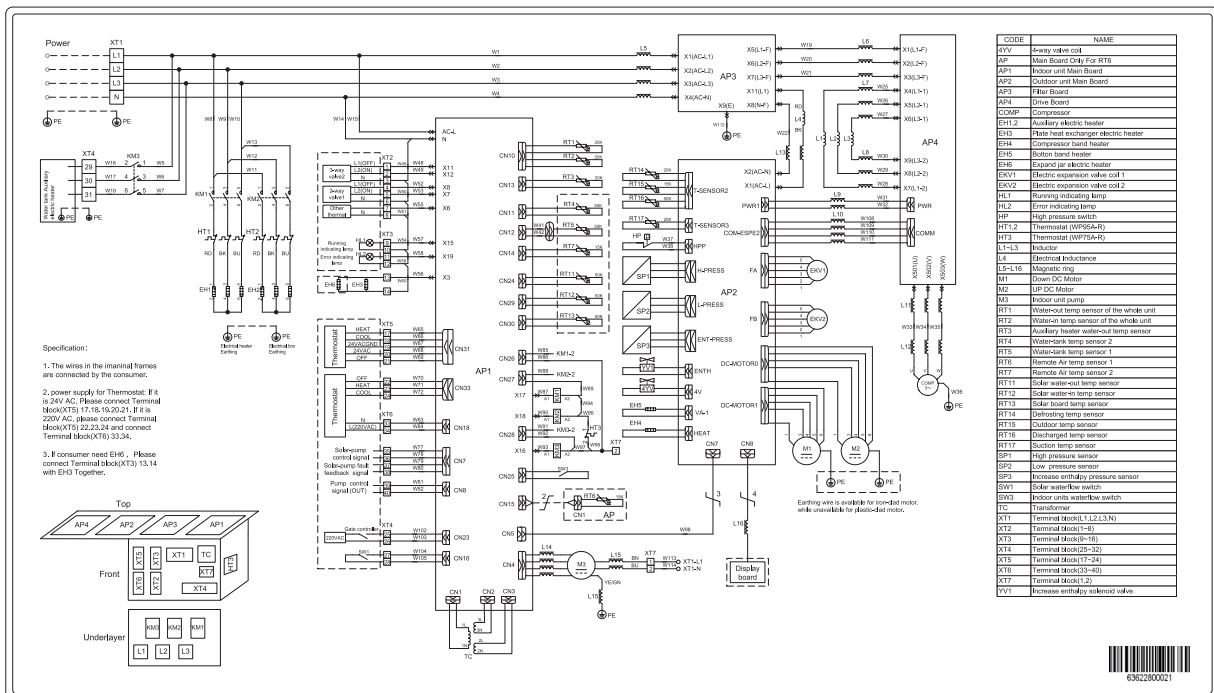

16.2.2 Terminal Board

(1) ML-RS-CQ8.0Pd/NaC-K, ML-RS-CQ10Pd/NaC-K

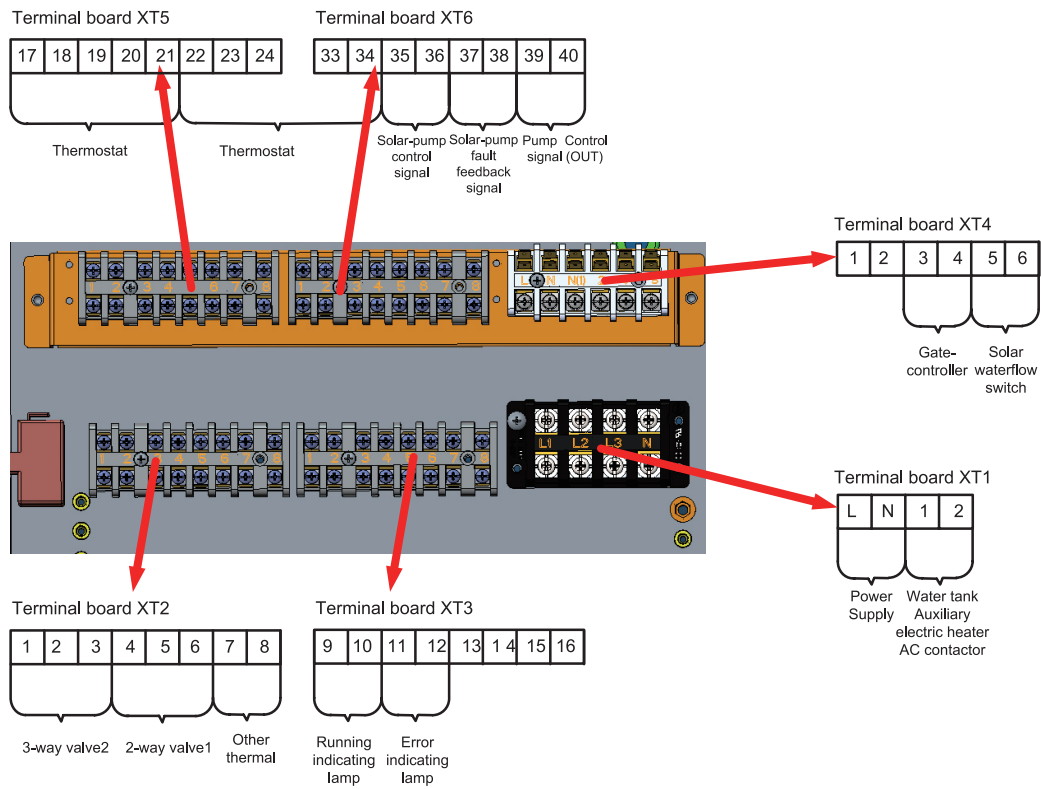

(2) ML-RS-CQ12Pd/NaC-M, ML-RS-CQ14Pd/NaC-M

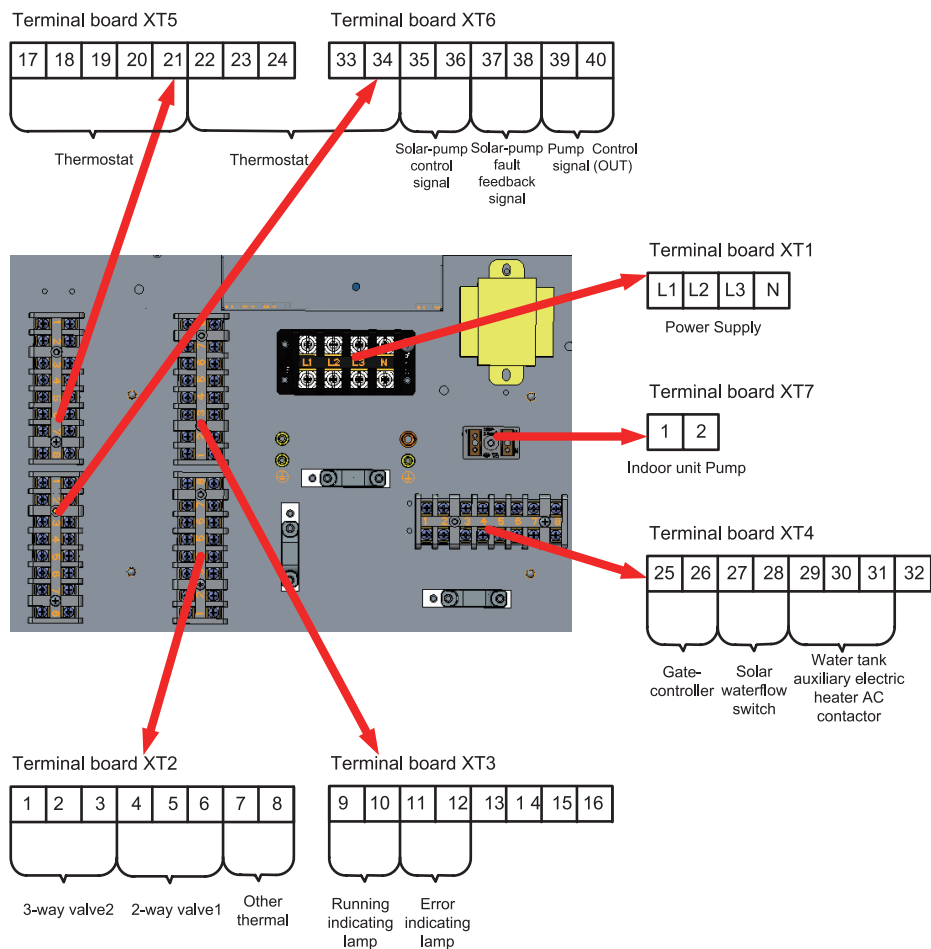

17. Commissioning

17.1 Check before startup

For safety of users and unit, the unit must be started up for check before debugging. The procedures are as below:

The following items shall be performed by qualified repair persons.		
Confirm together with the sales engineer, dealer, installing contractor and customers for the following items finished or to be finished.		
No.	Confirmation of Installation	√
1	If the contents of Application for Installation of this Unit by Installer are real. If not, debugging will be refused.	<input type="checkbox"/>
2	Is there written notice in which amendment items are shown in respect of unqualified installation?	<input type="checkbox"/>
3	Are Application for Installation and Debugging list filed together?	<input type="checkbox"/>
No.	Pre-check	√
1	Is appearance of the unit and internal pipeline system ok during conveying, carrying or installation?	<input type="checkbox"/>
2	Check the accessories attached with the unit for quantity, package and so on.	<input type="checkbox"/>
3	Make sure there is drawings in terms of electricity, control, design of pipeline and so on.	<input type="checkbox"/>
4	Check if installation of the unit is stable enough and there is enough space for operation and repair.	<input type="checkbox"/>
5	Completely test refrigerant pressure of each unit and perform leakage detection of the unit.	<input type="checkbox"/>
6	Is the water tank installed stably and are supports secure when the water tank is full?	<input type="checkbox"/>
7	Are heat insulating measures for the water tank, outlet/inlet pipes and water replenishing pipe proper?	<input type="checkbox"/>
8	Are the nilometer of water tank, water temperature indicator, controller, manometer, pressure relief valve and automatic discharge valve etc. installed and operated properly?	<input type="checkbox"/>
9	Does power supply accord with the nameplate? Do power cords conform to applicable requirements?	<input type="checkbox"/>
10	Is power supply and control wiring connected properly according to wiring diagram? Is earthing safe? Is each terminal stable?	<input type="checkbox"/>
11	Are connection pipe, water pump, manometer, thermometer, valve etc. are installed properly?	<input type="checkbox"/>
12	Is each valve in the system open or closed according to requirements?	<input type="checkbox"/>
13	Confirm that the customers and inspection personnel of Part A are at site.	<input type="checkbox"/>
14	Is Installation Check-up Table completed and signed by the installation contractor?	<input type="checkbox"/>
Attention: If there is any item marked with ×, please notify the contractor. Items listed above are just for reference.		
Confirmed Items after pre-checking	General Evaluation: Debugging <input type="checkbox"/> Amendment <input type="checkbox"/>	
	Judge the following items (if there is not any filling, qualification will be regarded.)	
	a: Power supply and electric control system	b: Loading calculation
	c: Heating problems of Unit	d: Noise problem
	e: Pipeline problem	f: Others
	Normal debugging work can't be performed unless all installation items are qualified. If there is any problem, it must be solved firstly. The installer will be responsible for all costs for delay of debugging and re-debugging incurred by any problem which is not solved immediately.	
	Submit schedule of amending reports to installer.	
	Is the written amending report which should be signed after communication provided to installer?	
Yes () No ()		

17.2 Test run

Test run is testing whether the unit can run normally via preoperation. If the unit cannot run normally, find and solve problems until the test run is satisfactory. All inspections must meet the requirements before performing the test run. Test run should follow the content and steps of the table below:

The following procedure should be executed by experience and qualified maintenance men.	
No.	Start up the pretest procedure
Notice: before test, ensure that all power must be cut off, including the far- end power switch, otherwise, it may cause casualty.	
1	Ensure that the compressor of the unit is preheated for 8h.
⚠Caution: heat the lubricating oil at least 8h in advance to prevent refrigerant from mixing with the lubricating oil, which may cause damage to the compressor when starting up the unit.	
2	Check whether the oil temperature of the compressor is obviously higher than the outdoor ambient temperature.
⚠Caution: if the oil temperature of the compressor is obviously higher than the outdoor ambient temperature, it means that the heating tape of compressor is damaged. In that case, the compressor will be damaged easily. Therefore, repair the heating tape before using the unit.	
3	Check whether the phase sequence of the main power supply is correct. If not, correct the phase sequence firstly.
⚠Recheck the phase sequence before start-up to avoid reverse rotation of the compressor which may damage the unit.	
4	Apply the universal electric meter to measure the insulation resistance between each outdoor phase and earth as well as between phases.
⚠Caution: defective earthing may cause electric shock.	
No.	Ready to start
1	Cut off all temporary power supply, resume all the insurance and check the electricity for the last time.
	Check the power supply and voltage of the control circuit; _____V must be $\pm 10\%$ within the range of rated operating power.
No.	Start up the unit
1	Check all the conditions needed to start up the unit: oil temperature, mode, required load etc.
2	Start up the unit, and observe the operation of compressor, electric expanding valve, fan motor and water pump etc.
	Note: the unit will be damaged under abnormal running state. Do not operate the unit in states of high pressure and high current.
Others:	
Items for acceptance after debugging	Estimation or suggestion on the general running situation: good, modify
	Identify the potential problem (nothing means the installation and debugging are in accordance with the requirements.)
	a. problem of power supply and electric control system:
	b. problem of load calculation:
	c. outdoor refrigerant system:
	d. noise problem:
	e. problem of indoor and piping system:
	h. other problems:
During operation, it is needed to charge for the maintenance due to non-quality problems such as incorrect installation and maintenance.	
Acceptance	
Is the user trained as required? Please sign. Yes() No()	

18. Daily Operation and Maintenance

In order to avoid damage of the unit, all protecting devices in the unit had been set before delivery, so please do not adjust or remove them.

For the first startup of the unit or next startup of unit after long-period stop (above 1 day) by cutting off the power, please electrify the unit in advance to preheat the unit for more than 8 hours.

Never put sundries on the unit and accessories. Keep dry, clean and ventilated around the unit.

Remove the dust accumulated on the condenser fin timely to ensure performance of the unit and to avoid stop of the unit for protection.

In order to avoid protection or damage of the unit caused by blockage of the water system, clean the filter in water system periodically and frequently check water replenishing device.

In order to ensure anti-freezing protection, never cut off the power if ambient temperature is below zero in winter.

In order to avoid frost crack of the unit, water in the unit and pipeline system not used for a long period should be drained. In addition, open the end cap of the water tank for drainage.

Never frequently make the unit on/off and close the manual valve of the water system during operation of the unit by users.

Ensure frequent check to the working condition of each part to see if there is oil stain at pipeline joint and charge valve to avoid leakage of refrigerant.

If malfunction of the unit is out of control of users, please timely contact with authorized service center.

Notes

(a) The water pressure gage is installed in the returning water line in the unit. Please adjust the hydraulics system pressure according to next item:

(b) If the pressure is less than 0.5 bar, please recharge the water immediately;

(c) When recharging, the hydraulics system pressure should be not more than 2.5Bar.

Troubleshooting

Malfunctions	Reasons	Troubleshooting
Compressor does not start up	Power supply has problem. Connection wire is loose. Malfunction of mainboard. Malfunction of compressor.	Phase sequence is reverse. Check out and re-fix. Find out the reasons and repair. Replace compressor.
Heavy noise of fan	Fixing bolt of fan is loose. Fan blade touches shell or grill. Operation of fan is unreliable.	Re-fix fixing bolt of fan. Find out the reasons and adjust. Replace fan.
Heavy noise of compressor	Liquid slugging happens when liquid refrigerant enters into compressor. Internal parts in compressor are broken.	Check if expansion valve is failure and temp. sensor is loose .If that, repair it. Replace compressor.
Water pump does not run or runs abnormally	Malfunction of power supply or terminal. Malfunction of relay. There is air in water pipe.	Find out the reasons and repair. Replace relay. Evacuate.
Compressor starts or stops frequently	Poor or excess refrigerant. Poor circulation of water system. Low load.	Discharge or add part of refrigerant. Water system is blocked or there is air in it.Check water pump, valve and pipeline. Clean water filter or evacuate. Adjust the load or add accumulating devices.
The unit does not heat although compressor is running	Leakage of refrigerant. Malfunction of compressor.	Repair by leakage detection and add refrigerant. Replace compressor.
Poor efficiency of hot water heating	Poor heat insulation of water system. Poor heat exchange of evaporator. Poor refrigerant of unit. Blockage of heat exchanger at water side.	Enhance heat insulation efficiency of the system. Check if air in or out of unit is normal and clean evaporator of the unit. Check if refrigerant of unit leaks. Clean or replace heat exchanger.

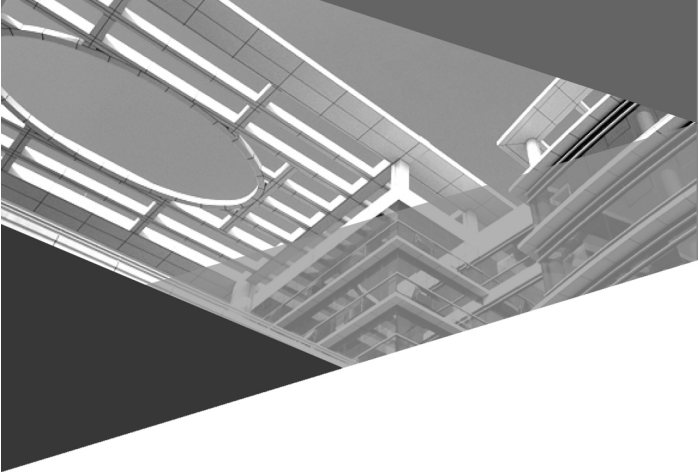

MegaLife

www.megalife.ma

Made BY ML ELECTRONICS



66129936526